



# Installation and Operations Manual

H-IM-SCU-LT

October 2017

Part No. 25008401

## Screw Compressor Condensing Units Low Temperature Models



### Table of Contents

General Safety Information . . . . .	2	Line Sizing . . . . .	9-12
Inspection . . . . .	2	Evacuation and Leak Detection . . . . .	12
Warranty Statement . . . . .	2	Refrigerant Charging Instructions . . . . .	12
Space and Location Requirements . . . . .	3	Field Wiring . . . . .	12
Condensing Unit Rigging and Mounting . . . . .	4	C450 System Control & Adjustment . . . . .	13-14
Head Pressure Control . . . . .	5	Check Out and Start Up . . . . .	15
Refrigerant Oil Type . . . . .	5	Operational Check Out . . . . .	15
Recommended Refrigerant Piping Practices . . . . .	7	System Balancing - Compressor Superheat . . . . .	16
Refrigerant Pipe Support . . . . .	7	System Troubleshooting Guide . . . . .	18
Suction Lines . . . . .	7	Preventive Maintenance Guidelines . . . . .	18
Liquid Lines . . . . .	8	Wiring Diagrams . . . . .	19-26
Unit Cooler Piping . . . . .	8	Interlink™ Replacement Parts . . . . .	30

## General Safety Information

1. Installation and maintenance to be performed only by qualified personnel who are familiar with this type of equipment.
2. All units are pressurized with dry air or inert gas. All units must be evacuated before charging the system with refrigerant.
3. Make sure that all field wiring conforms to the requirements of the equipment and all applicable national and local codes.
4. Avoid contact with sharp edges and coil surfaces. They are a potential injury hazard.
5. Make sure all power sources are disconnected before any service work is done on units.
6. Oil to charge oil separator and oil cooler shipped loose.

**WARNING:** *Refrigerant can be harmful if it is inhaled. Refrigerant must be used and recovered responsibly. Failure to follow this warning may result in personal injury or death. No oil installed in condensing unit as shipped from factory. Oil must be charged before operating.*

**NOTE:** *SSV and DSV condensing units are designed for operation with DX evaporators only, and is not designed to be applied with flooded or liquid recirculating evaporators. Applications of Heatcraft SSV and DSV Screw condensing units with evaporators that are not DX are not the responsibility of, and will not be supported by Heatcraft Refrigeration Products.*

## Inspection

Responsibility should be assigned to a dependable individual at the job site to receive material. Each shipment should be carefully checked against the bill of lading. The shipping receipt should not be signed until all items listed on the bill of lading have been accounted for. Check carefully for concealed damage. Any shortage or damages should be reported to the delivering carrier. Damaged material becomes the delivering carrier's responsibility, and should not be returned to the manufacturer unless prior approval is given to do so. When uncrating, care should be taken to prevent damage. Heavy equipment should be left on its shipping base until it has been moved to the final location. Check the serial tag information with invoice. Report any discrepancies to your Heatcraft Refrigeration Products Sales Representative.

## Warranty Statement

Seller warrants to its direct purchasers that products, including Service Parts, manufactured by SELLER shall be of a merchantable quality, free of defects in material or workmanship, under normal use and service for a period of one (1) year from date of original installation, or eighteen (18) months from date of shipment by SELLER, whichever first occurs. Any product covered by this order found to Seller's satisfaction to be defective upon examination at Seller's factory will at SELLER's option, be repaired or replaced and returned to Buyer via lowest common carrier, or SELLER may at its option grant Buyer a credit for the purchase price of the defective article. Upon return of a defective product to SELLER's plant, freight prepaid, by Buyer, correction of such defect by repair or replacement, and return freight via lowest common carrier, shall constitute full performance by SELLER of its obligations hereunder.

SELLER shall have no liability for expenses incurred for repairs made by Buyer except by prior, written authorization. Every claim on account of breach of warranty shall be made to SELLER in writing within the warranty period specified above – otherwise such claim shall be deemed waived. Seller shall have no warranty obligation whatsoever if its products have been subjected to alteration, misuse, negligence, free chemicals in system, corrosive atmosphere, accident, or if operation is contrary to SELLER's or manufacturer's recommendations, or if the serial number has been altered, defaced, or removed.

## Motor Compressors

Motor compressors furnished by SELLER are subject to the standard warranty terms set forth above, except that motor compressor replacements or exchanges shall be made through the nearest authorized wholesaler of the motor compressor manufacturer (not at SELLER's factory) and no freight shall be allowed for transportation of the motor compressor to and from the wholesaler. The replacement motor compressor shall be identical to the model of the motor compressor being replaced. Additional charges which may be incurred throughout the substitution of other than identical replacements are not covered by this warranty. An optional, non assignable, four (4) year extended compressor warranty may be purchased within the boundaries of the United States of America, its territories and possessions, and Canada. With this extended compressor warranty, replacements are administered by an authorized compressor distributor only. Replacements within the first year of the warranty area available through the distributor; the second through fifth years, the

purchaser must submit a proof-of-purchase of a compressor and supply it to Heatcraft Refrigeration Products Warranty Claims for reimbursement.

Seller makes no express warranties except as noted above. All implied warranties are limited to the duration of the Express Warranty. Liability for incidental and consequential damages is excluded.

The forgoing is in lieu of all other warranties, express or implied, notwithstanding the provisions of the uniform commercial code, the Magnuson-Moss Warranty - Federal Trade Commission Improvement Act, or any other statutory or common law, federal or state.

SELLER makes no warranty, express or implied, of fitness for any particular purpose, or of any nature whatsoever, with respect to products manufactures or sold by seller hereunder, except as specifically set forth above and on the face hereof. It is expressly understood and agreed that SELLER shall not be liable to buyer, or any customer of buyer, for direct or indirect, special, incidental, consequential or penal damages, or for any expenses incurred by reason of the use or misuse by buyer or third parties of said products. To the extent said products may be considered "consumer products," As defined in Sec. 101 of the Magnuson-Moss Warranty - Federal Trade Commission Improvement Act, SELLER makes no warranty of any kind, express or implied, to "consumers," except as specifically set forth above and on the face hereof.

The following conditions should be adhered to when installing this unit to maintain the manufacturer's warranty:

1. System piping must be in accordance with good refrigeration practices.
2. **Inert gas must be charged into the piping during brazing.**
3. The power supply to the unit must meet the following conditions:
  - a. Three phase voltages must be +/- 10% of nameplate ratings.
  - b. Phase imbalance cannot exceed 2%.
4. All control and safety switch circuits must be properly connected according to the wiring diagram.
5. The factory installed wiring and piping must not be changed without written factory approval.
6. All equipment is installed in accordance with Heatcraft Refrigeration Products specified minimum clearances.
7. Oil charge not to be added directly into the compressors! Oil cooler must be charged with oil injection line solenoid closed. Open all shutoff valves on oil separator and oil cooler oil must be charged directly into the oil separator and oil cooler before evacuation. Charge separator until oil is within its sight glass range.

## Space and Location Requirements for Air Cooled Condensing Units

The most important consideration which must be taken into account when deciding upon the location of air-cooled equipment is the provision for a supply of ambient air to the condenser, and removal of heated air from the condensing unit or remote condenser area. Where this essential requirement is not adhered to, it will result in higher head pressures, which cause poor operation and potential failure of equipment. Units must not be located in the vicinity of steam, hot air or fume exhausts. Corrosive atmospheres require custom designed condensers.

Another consideration which must be taken is that the unit should be mounted away from noise sensitive spaces and must have adequate support to avoid vibration and noise transmission into the building. Units should be mounted over corridors, utility areas, rest rooms and other auxiliary areas where high levels of sound are not an important factor. Sound and structural consultants should be retained for recommendations.

### Walls or Obstructions

The unit should be located so that air may circulate freely and not be recirculated. For proper air flow and access all sides of the unit should be a minimum of "W" away from any wall or obstruction. It is preferred that this distance be increased whenever possible. Care should be taken to see that ample room is left for maintenance work through access doors and panels. Overhead obstructions are not permitted. When the unit is in an area where it is enclosed by three walls the unit must be installed as indicated for units in a pit.

Figure 1. Clearance From Walls or Obstructions

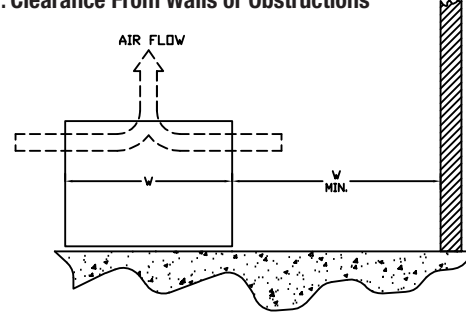

### Multiple Units

For units placed side by side, the minimum distance between units is the width of the largest unit. If units are placed end to end, the minimum distance between units is 4 feet.

Figure 2. Clearance For Multiple Units Placed Side by Side

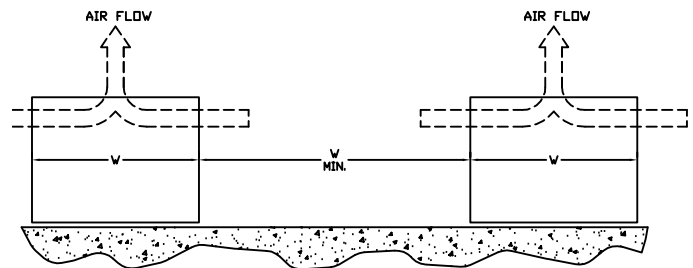

### Units in Pits

The top of the unit should be level with the top of the pit, and side distance increased to "2W". If the top of the unit is not level with the top of pit, discharge cones or stacks must be used to raise discharge air to the top of the pit. This is a minimum requirement.

Figure 3. Clearance For Units in Pits

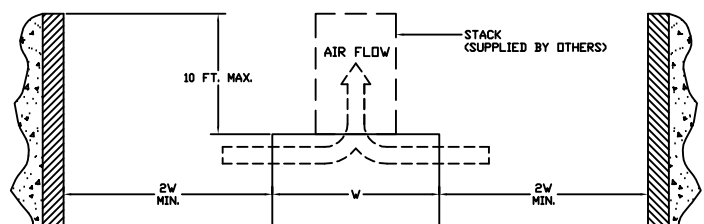

### Decorative Fences

Fences must have 50% free area, with 1 foot undercut, a "W" minimum clearance, and must not exceed the top of unit. If these requirements are not met, unit must be installed as indicated for "Units in Pits".

Figure 4. Clearance For Fence Enclosures

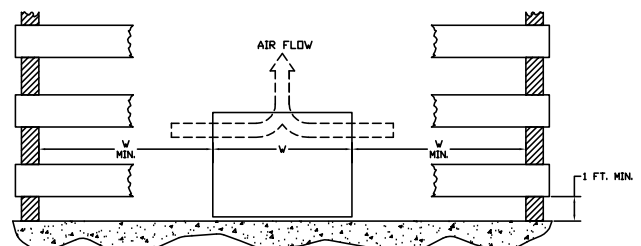

## Condensing Unit Rigging and Mounting

Rigging holes are provided on all units. Caution should be exercised when moving these units. To prevent damage to the unit housing during rigging, cables or chains used must be held apart by spacer bars. The mounting platform or base should be level and located so as to permit free access of supply air.

### Rigging And Handling

1. Rig unit as shown. Use spreader bar to protect cabinet.
2. Avoid rough handling and shock to the unit

### Location And Mounting

1. If possible locate units over or outside of utility areas, corridors or auxiliary spaces to reduce the transmission of sound and vibration to occupied spaces.
2. Use vibration isolators if unit must be mounted where transmission of sound or vibration is of concern.
3. Install roof-mounted units on steel channels or I-beams to support the unit above the roof.
4. For ground level installations, concrete slab with footings extending below the frost line is recommended.
5. Provide at least 4 feet of clearance on the air inlet and discharge sides of the unit
6. Do not attach duct work to coil inlet or fan outlets.
7. Avoid conditions that could cause air recirculation such as sight screening, walls, etc.
8. Do not locate unit so that air discharge is towards building air intakes.

Figure 5. - Rigging

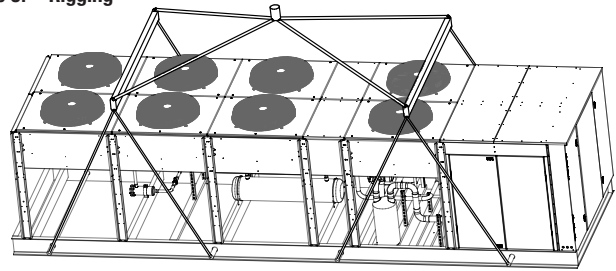

### Approx. Unit Weights

"Model Numbers"	"Approx. Net Weight (Lbs./Kg.)"	
SSV060BL6*	8,301	3,765
SSV070BL6*	8,438	3,827
DSV080BL6*	10,833	4,914
DSV100BL6*	11,568	5,247
DSV120BL6*	12,726	5,772
DSV140BL6*	14,035	6,366

### Ground Mounting

Concrete slab raised six inches above ground level provides a suitable base. Raising the base above ground level provides some protection from ground water and wind-blown matter. Before tightening mounting bolts, recheck level of unit. The unit should in all cases be located with a clear space in all directions that is at a minimum, equal to the height of the unit above the mounting surface. A condensing unit mounted in a corner formed by two walls, may result in discharge air recirculation with resulting loss of capacity.

### Roof Mounting

Due to the weight of the units, a structural analysis by a qualified engineer may be required before mounting. Roof mounted units should be installed level on steel channels or an I-beam frame capable of supporting the weight of the unit. Vibration absorbing pads or springs should be installed between the condensing unit legs or frame and the roof mounting assembly.

### Access

Sufficient access must be provided to ensure future service of all major components is possible. The screw compressor, as well as some of the compressors removable components are heavy enough to require additional lifting equipment for service. Care must be taken during condensing unit placement to accommodate the use of service equipment for maintenance or repair.

### Pad Mounted Compressor

All units use pad mounted compressors. Check the compressor mounting bolts to insure they have not vibrated loose during shipment. See Figure 7.

Figure 6. Pad Mount / Anti-Vibration Mount

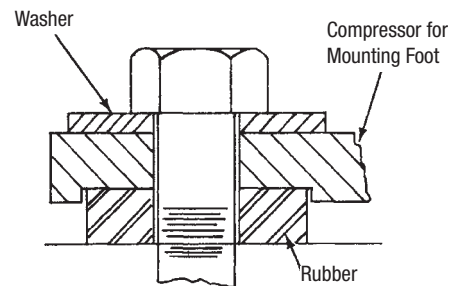

### Cabinet Installation

Sheet metal covers between oil cooler and air-cooled condenser are shipped loose and are to be installed after condensing unit is fully installed on ground or roof mount (see section above, "Location And Mounting" for mounting instructions).

## Head Pressure Control

The means of head pressure control available on these condensing units are the following:

- Dual Valve System. (See "Operation and Adjustment" section on page 5.)
- Pressure Fan Cycle Control. (See "Operation and Adjustment" section on page 5.)
- Variable Speed Fan Control (Optional)

Fan management is constantly monitored and adjusted by the controller to maintain the target head pressure

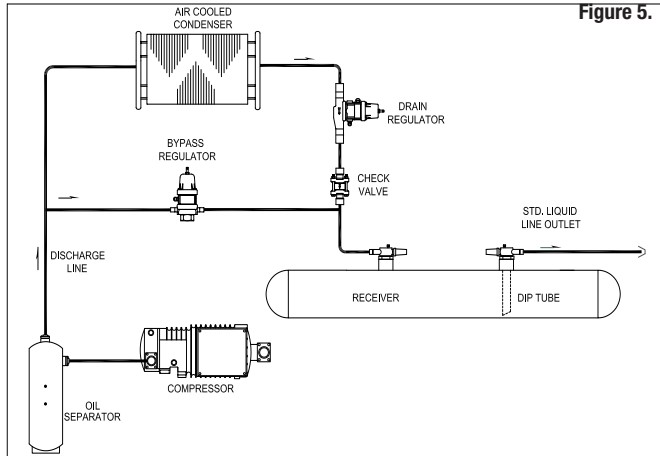

### a. Dual Valve System

The system employs A8 and A9 valves. The high pressure discharge gas is introduced above the liquid in the receiver tank. The receiver discharge is regulated by the A8 and A9 valve.

The discharge pressure of the A8 valve must be adjusted to regulate the unit for proper operating conditions. Adjust the A8 valve shown in Figure 5 to maintain a discharge pressure of 160 to 180 PSIG. "flooding" of the condenser with liquid refrigerant reduces the available condensing surface, holding the condensing pressure at the valve setting.

### b. Pressure Fan Cycle Control

The cycling of condenser fans provides an automatic means of maintaining head pressure control, within reasonable limits, at lower ambient air temperatures. A fan cycling control system allows fans to cycle in sequence by sensing either ambient temperature or condensing pressures. However, care must be used by the engineer or installing contractor in making adjustments to prevent short cycling of the fan motors. Short cycling is normally caused by too close a differential in the control settings or set points. If flooding valves are used with fan cycling, they must be set to follow the fan cycling. Recommended differential settings for pressure cycling is a minimum of 35 PSIG. However, system or climate conditions vary and the controls may require further field adjustment to provide optimum system performance and prevent short cycling. Any fan cycle that is less than three minutes is considered short cycling, and could be detrimental to the system.

### c. Fan Speed Modulation (Optional)

Condenser head pressure control is provided by varying the air flow through the condenser by changing the RPM of the condenser fan(s). system or climate conditions vary and the controls may require further field adjustment to provide optimum system performance and prevent excessive ramping and deceleration of fan speed in response to head pressure

## Capacity Control / Loader Staging

Compressor	100%	75%	50%
HSN-64	CR1 = ON CR2 = ON	CR1 = OFF CR2 = ON	CR1 = OFF CR2 = OFF
HSN-74	CR1 = ON CR2 = ON	CR1 = ON CR2 = OFF	CR1 = OFF CR2 = OFF

**NOTE: Mechanical subcooler/economizer not energized during 50% operation**

## Operation and Adjustment

Condensing units with dual valves require sufficient charge to partially flood the condenser during low ambient conditions. (See Flooded Refrigerant Charge Table below)

For the two-valve head pressure controls, adjustment should be made with gauges connected to the discharge port of the compressor. Adjustments should be made during mild or low ambient conditions. First, loosen the seal nut before attempting to turn the adjustment screw. Turning the adjustment screw "clockwise" on the A8 valve will raise the set point, while turning the valve stem "counterclockwise" will lower the set point. One full revolution of the adjusting screw will change the set point 70 psi. Once desired pressure set point is reached, re-tighten the seal nut.

If adjustments are made during warm ambient conditions, it may not be possible to adjust the regulator valve as low as desired. Readjustment may be necessary once cooler conditions prevail.

**Table 1. Range Of Liquid Temperatures (Dependent Upon Refrigerant Type)**

	SSV060L6*	SSV070L6*	DSV080L6*	DSV100L6*	DSV120L6*	DSV140L6*
0°F	45-70°F	49-75°F	42-60°F	45-70°F	45-70°F	49-75°F
-10°F	36-61°F	40-67°F	33-55°F	35-60°F	36-62°F	40-67°F
-15°F	32-57°F	35-62°F	28-49°F	30-55°F	32-57°F	35-62°F
-20°F	27-52°F	30-57°F	23-45°F	26-50°F	27-53°F	30-57°F
-30°F	18-43°F	20-47°F	14-34°F	21-40°F	18-43°F	21-47°F
-40°F	9-32°F	14-37°F	5-23°F	6-29°F	9-33°F	11-37°F

**Table 2. Flooded Charge (@-20°F Ambient)**

	SSV060L6*	SSV070L6*	DSV080L6 *(PER CIRCUIT)	DSV100L6 *(PER CIRCUIT)	DSV120L6 *(PER CIRCUIT)	DSV140L6 *(PER CIRCUIT)
R404A	123	123	133	117	157	176
R507	123	123	133	117	157	176
R407A	128	128	138	121	164	183
R407F	132	132	142	125	168	188
R448A	129	129	139	123	165	185
R449A	129	129	139	123	165	185

## Refrigerant Oil Type

BITZER Semi-Hermetic Screws are available in standard HSN models for low temperature condensing applications. These compressors offer excellent part and full load efficiencies.

A key aspect to utilizing these compressors to their fullest potential is specifying the correct oil for your refrigerant. HSN screws use BSE 170 oil in a variety of refrigerants (R404A, R507A, R407A, R407F, R448A, and R449A).

## Compressor Ports

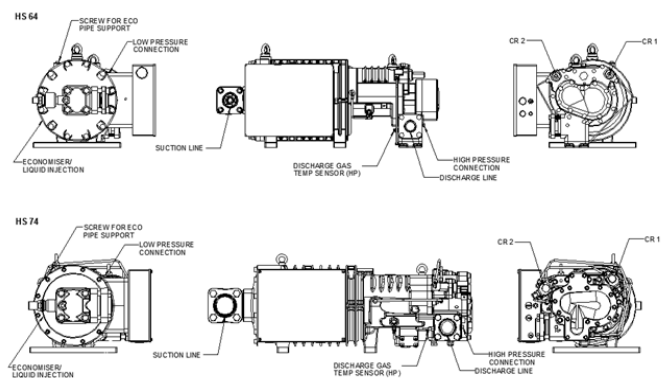



## Polyol Ester Lubricants Hygroscopicity

Ester lubricants (POE) have the characteristic of quickly absorbing moisture from the ambient surroundings. This is shown graphically in Figure 9 where it can be seen that such lubricants absorb moisture faster and in greater quantity than conventional mineral oils. Since moisture levels greater than 100 ppm will result in system corrosion and ultimate failure, it is imperative that compressors, components, containers and the entire system be kept sealed as much as possible. Lubricants will be packaged in specially designed, sealed containers. After opening, all the lubricant in a container should be used at once since it will readily absorb moisture if left exposed to the ambient. Any unused lubricant should be properly disposed of. Similarly, work on systems and compressors must be carried out with the open time as short as possible. Leaving the system or compressor open during breaks or overnight **MUST BE AVOIDED!**

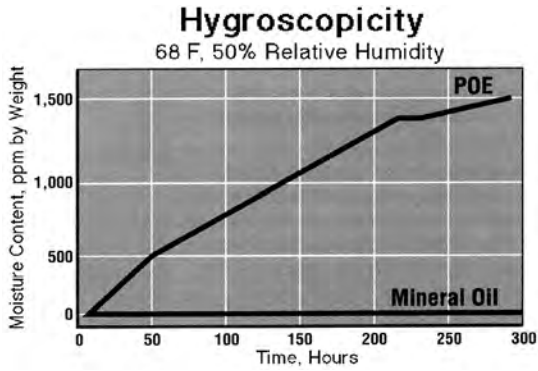

## Oil-Cooler Arrangement

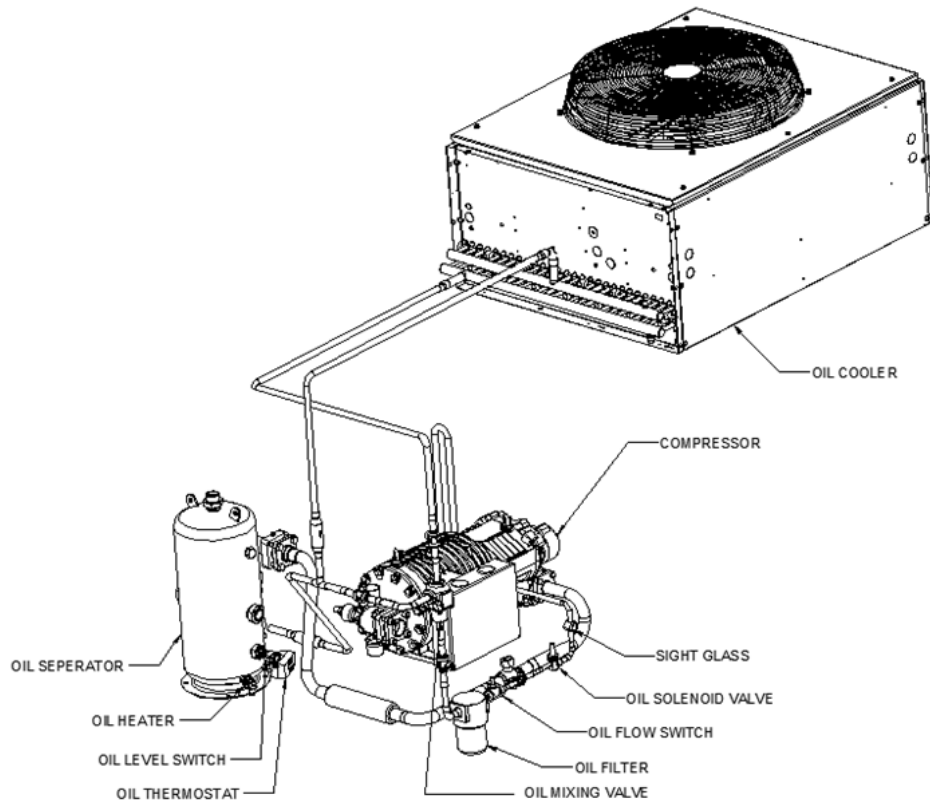

## Color

As received, the POE lubricant will be clear or straw colored. After use, it may acquire a darker color. This does not indicate a problem as the darker color merely reflects the activity of the lubricant's protective additive.

## Oil Level

The oil separator heater(s) supplied with condensing unit must be turned on 24 hours before startup.

Oil level must be full on bottom sight-glass and 1/4 full on top sight-glass.

## Compressor Protection Device

The Compressor protection module protects the compressor based upon the following monitored inputs:

- Winding temperature (PTC)
- Discharge gas temperature (PTC)
- Rotating direction / phase sequence
- Cable breakage in the PTC sensor circuit
- Monitoring phase failure / phase asymmetry
- Limits number of motor starts.

## Phase Loss Monitor

The combination phase sequence and loss monitor relay protects the system against phase loss (single phasing), phase reversal (improper sequence) and low voltage (brownout). When phase sequence is correct and full line voltage is present on all three phases, the relay is energized as the normal condition indicator light glows.

**Note:** If compressor fails to operate and the normal condition indicator light on the phase monitor does not glow, then the supplied electrical current is not in phase with the monitor. This problem is easily corrected by the following steps:

1. Turn power off at disconnect switch.
2. Swap any two of the three power input wires feeding into the power distribution block. **Note:** Do not swap leads at the phase monitor. Swapping leads at the phase monitor could result in compressor and system damage.
3. Turn power on. Indicator light should glow and compressor should start.
4. Observe motors for correct rotation.

## Recommended Refrigerant Piping Practices

The system as supplied by Heatcraft Refrigeration Products, was thoroughly cleaned and dehydrated at the factory. Foreign matter may enter the system by way of the evaporator to condensing unit piping. Therefore, care must be used during installation of the piping to prevent entrance of foreign matter.

Install all refrigeration system components in accordance with applicable local and national codes and in conformance with good practice required for the proper operation of the system.

The refrigerant pipe size should be selected from the Line Sizing Tables. The interconnecting pipe size is not necessarily the same size as the stub-out on the condensing unit or the evaporator.

The following procedures should be followed:

1. Do not leave dehydrated compressors or filter-driers on condensing units open to the atmosphere any longer than is absolutely necessary.
2. Use only refrigeration grade copper tubing, properly sealed against contamination.
3. Suction lines should slope 1/4" per 10 feet towards the compressor.
4. Suitable P-type oil traps should be located at the base of each suction riser to enhance oil return to the compressor.
5. For desired method of superheat measurement, a pressure tap

Figure 7. Example of Pipe Support

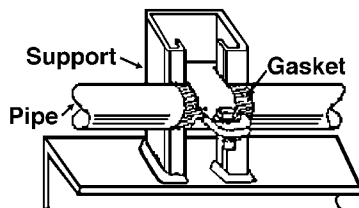

should be installed in each evaporator suction line in the proximity of the expansion valve bulb

Figure 8. Condensing Unit / Compressor to Wall Support

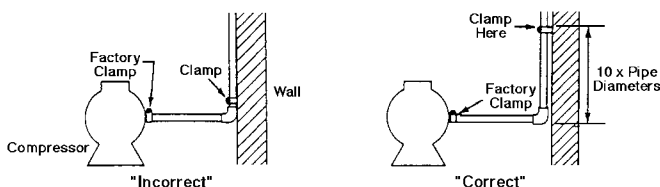

6. When brazing refrigerant lines, an inert gas should be passed through the line at low pressure to prevent scaling and oxidation

inside the tubing. Dry nitrogen is preferred.

7. Use only a suitable silver solder alloy on suction and liquid lines.
8. Limit the soldering paste or flux to the minimum required to prevent contamination of the solder joint internally. Flux only the male portion of the connection, never the female. After brazing, remove excess flux.
9. If isolation valves are installed at the evaporator, full port ball valves should be used.

## Refrigerant Pipe Support

1. Normally, any straight run of tubing must be supported in at least two locations near each end of the run. Long runs require additional supports. The refrigerant lines should be supported and fastened properly. As a guide, 3/8 to 7/8 should be supported every 5 feet; 1-1/8 every 7 feet; and 1-5/8 and 2-1/8 every 9 to 10 feet.
2. When changing directions in a run of tubing, no corner should be left unsupported. Supports should be placed a maximum of 2 feet in each direction from the corner.
3. Piping attached to a vibrating object (such as a compressor or compressor base) must be supported in such a manner that will not restrict the movement of the vibrating object. Rigid mounting will fatigue the copper tubing
4. Do not use short radius ells. Short radius elbows have points of excessive stress concentration and are subject to breakage at these points.
5. Thoroughly inspect all piping after the equipment is in operation and add supports wherever line vibration is significantly greater than most of the other piping. Extra supports are relatively inexpensive as compared to refrigerant loss.

## Suction Lines

Horizontal suction lines should slope away from the evaporator toward the compressor at the rate of 1/4 inch per 10 feet for good oil return. When multiple evaporators are connected in series using a common suction line, the branch suction lines must enter the top of the common suction line.

For dual or multiple evaporator systems, the branch lines to each evaporator should be sized for the evaporator capacity. The main common line should be sized for the total system capacity.

Suction lines that are outside of refrigerated space must be insulated. See the "Line Insulation" section on page 12 for more information.

Figure 9. Suction P-Traps

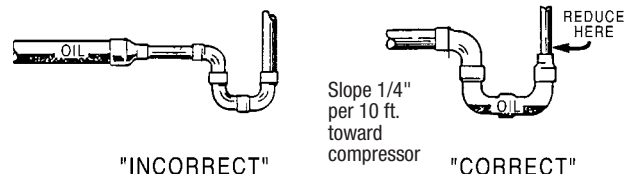

## Suction Line Risers

Prefabricated wrought copper traps are available, or a trap can be made by using two street ells and one regular ell. The suction trap must be the same size as the suction line. For long vertical risers, additional traps may be necessary. Generally, one trap is recommended for each length of pipe (approximately 20 feet) to insure proper oil movement. See Figure 12 for methods of constructing proper suction line P-traps.

**Figure 11. Double Suction Riser Construction**

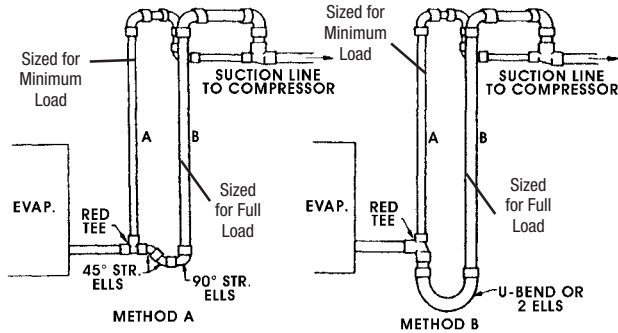

**NOTE:** A suction line trap must be installed at the point where piping changes the direction of refrigerant flow from any horizontal run to an upward vertical run.

## Liquid Lines

Liquid lines should be sized for a minimum pressure drop to prevent “flashing”. Flashing in the liquid lines would create additional pressure drop and poor expansion valve operation. Condensing unit comes supplied with factory installed mechanical subcooling through the brazed plate heat exchanger.

The solenoid supplying liquid refrigerant to feed the heat exchanger expansion valve only is energized when compressor has at least one loader energized.

Condensing unit comes with ball valves shut preventing liquid from flowing to the heat exchanger expansion valve.

Subcooled liquid temperature supplied by heat exchanger dependent upon design conditions and refrigerant type (see Table 9 on page 5)

It is recommended that liquid lines are insulated between heat exchanger and evaporators.

The liquid line solenoid should be installed.

**NOTE:** Evaporator expansion valve and nozzle selection should be made based upon the design liquid temperature provided in Table 9 on page 16.

## Unit Cooler Piping

### Pipe size example:

Given: **-10°F Freezer** with one system having (2) evaporators

- One condensing unit rated at 24,000 BTUH's @ -20°F SST R404A refrigerant.
- Two evaporators each rated at 12,000 BTUH's @ 10°F TD.
- 100 feet of actual line run between condensing unit to first evaporator and 20 feet of actual line run between the first evaporator and the second evaporator (see Figure 12 below).

### How to figure line sizes:

1. Determine equivalent line run = actual run + valves and fitting allowances.
2. Use Line Sizing Tables to size lines.
3. Note any special considerations.

**Figure 10. Pipe Size Example**

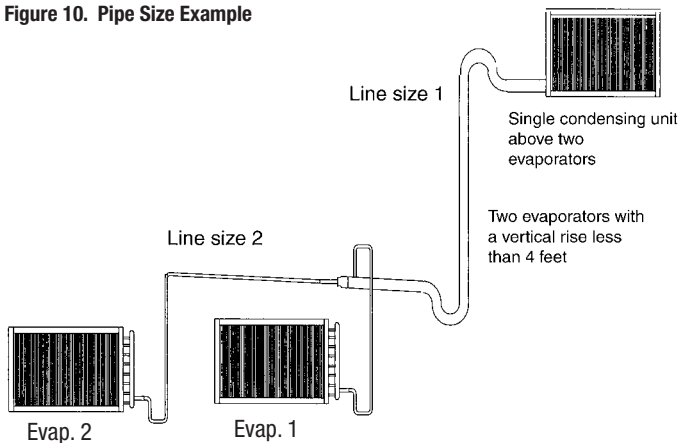

### Fittings in this system:

- (6) 90° elbows in main line plus a 90° turn through a tee.
- (5) additional 90° elbows to first evaporator.
- (4) additional 90° elbows to second evaporator.

### Determine line size 1 (main line from condensing unit):

1. Main line from the condensing unit to be sized for the total capacity (balance) of the whole system of 24,000 BTUH's (Table 4)
2. Refer to 24,000 @100 feet at -20°F SST R404A on the chart. You will find the suction line to be 1-3/8" and 1/2" liquid line.
3. Refer to Table 3. For every 1-3/8" 90° elbow you must add 4 equivalent feet of pipe and 2.5 equivalent feet of pipe for each 1-3/8" tee.

Therefore, total equivalent line run =

Actual line run	100 feet
+ (6) 1-3/8" elbows @ 4'	24 feet
+ (1) 1-3/8" tee @ 2.5'	2.5 feet
<b>Total equivalent line run</b>	<b>126.5 feet</b>

4. Refer to Table 3. For 126.5 total equivalent feet, the suction line size should be 1-3/8" and the liquid line stays at 1/2" line.

**Note:** The gray shaded areas on Table 4. For 24,000 BTUH's, the maximum suction riser is 1-1/8" to insure proper oil return and pressure drop from the bottom p-trap to the top p-trap.

### Determine line size 2 (evaporators):

1. Line sizing to each evaporator is based on 12,000 BTUH's and equivalent run from condensing unit. First evaporator has a 105 ft. run and the second evaporator has a 120 ft. run.
2. Table 4 indicates 1-1/8" suction for the first evaporator and indicates 1-1/8" suction for the second evaporator.
3. Refer to Table 3. Each 1-1/8" 90° elbow adds 3 equivalent feet of pipe. Each 90° turn through a 1-1/8" tee adds 6 equivalent feet.

4. Actual line run (evap 1) 105 feet
 

+ (5) 1-1/8" elbows @ 3'	15 feet
+ (1) 90° turn through tee @ 6'	6 feet
<b>Total equivalent line run</b>	<b>126 feet</b>

Actual line run (evap 2)	120 feet
+ (4) 1-1/8" elbows @ 3'	12 feet
<b>Total equivalent line run</b>	<b>132 feet</b>

5. Table 4 indicates 1-1/8" suction line and 3/8" liquid line from main line to both evaporators.



## Line Sizing

The following Table 4 and Table 5 indicate liquid lines and suction lines for all condensing units for R404A, R507A, R407A, R407F, R448A, and R449A.

When determining the refrigerant line length, be sure to add an allowance for fittings. See Table 2. Total equivalent length of refrigerant lines is the sum of the actual linear footage and the allowance for fittings.

**Table 3. Weight of Refrigerants in Copper Lines During Operation (Pounds per 100 lineal feet of type "L" tubing)**

Line Size O.D. (Inches)	Refrigerant	Liquid Line	Hot Gas Line	Suction Line at Suction Temperature				
				-40°F	-20°F	0°F	+20°F	+40°F
1-1/8	R-407	23.8	2.60	0.10	0.16	0.25	0.37	0.54
	R-448A/R-449A	38.4	2.53	0.17	0.27	0.42	0.63	0.92
	R-507, 404A	36.1	3.27	0.26	0.39	0.63	0.86	1.24
1-3/8	R-407	40.7	3.96	0.17	0.27	0.43	0.63	0.93
	R-448A/R-449A	58.4	3.85	0.25	0.41	0.64	0.96	1.40
	R-507, 404A	55.0	4.98	0.40	0.58	0.95	1.32	1.87
1-5/8	R-407	61.8	5.61	0.26	0.41	0.65	1.96	1.43
	R-448A/R-449A	82.7	5.45	0.36	0.58	0.90	1.36	1.98
	R-507, 404A	78.0	7.07	0.56	0.82	1.35	1.86	2.64
2-1/8	R-407	87.4	9.76	0.36	0.57	0.91	1.38	2.01
	R-448A/R-449A	143.8	9.48	0.62	1.01	1.57	2.36	3.44
	R-507, 404A	134	12.25	0.98	1.43	2.35	3.23	4.58
2-5/8	R-407	152	15.05	0.63	1.00	1.60	2.38	3.49
	R-448A/R-449A	222	14.62	0.96	1.56	2.42	3.65	5.30
	R-507, 404A	209	18.92	1.51	2.21	3.62	5.00	7.07
3-1/8	R-407	235	21.48	0.98	1.55	2.46	3.67	5.39
	R-448A/R-449A	317	20.86	1.37	2.22	3.45	5.20	7.57
	R-507, 404A	298	27.05	2.16	3.15	5.17	7.14	9.95
3-5/8	R-407	345	29.05	1.40	2.23	3.50	5.23	8.27
	R-448A/R-449A	428	28.22	1.86	3.01	4.67	7.04	10.24
	R-507, 404A	403	36.50	2.92	4.25	6.97	19.65	13.67
4-1/8	R-407	589	37.60	2.45	3.92	6.17	17.80	9.23
	R-448A/R-449A	554	36.53	2.40	3.89	6.05	9.11	13.25
	R-507, 404A	526	47.57	3.80	5.55	9.09	12.58	17.80

**Table 4. Equivalent Feet of Pipe Due to Valve and Fitting Friction**

Copper Tube, O.D., Type "L"	1/2	5/8	7/8	1-1/8	1-3/8	1-5/8	2-1/8	2-5/8	3-1/8	3-5/8	4-1/8	5-1/8	6-1/8
Globe Valve (Open)	14	16	24	28	36	42	57	69	83	99	118	138	168
Angle Valve (Open)	7	9	12	15	18	21	28	34	42	49	57	70	83
90° Turn Through Tee	3	4	5	6	8	9	12	14	17	20	24	28	34
Tee (Straight Through) or Sweep Below	.75	1	1.5	2	2.5	3	3.5	4	5	6	7	9	11
90° Elbow or Reducing Tee (Straight Through)	1	2	2	3	4	4	5	7	8	10	12	14	16

**Table 5. Pressure Loss of Liquid Refrigerants in Liquid Line Risers (Expressed in Pressure Drop, PSIG, and Subcooling Loss, °F)**

Refrigerant	Liquid Line Rise in Feet																	
	10'		15'		20'		25'		30'		40'		50'		75'		100'	
	PSIG	°F	PSIG	°F	PSIG	°F	PSIG	°F	PSIG	°F	PSIG	°F	PSIG	°F	PSIG	°F	PSIG	°F
R-407	4.3	1.4	6.4	2.0	8.5	2.7	10.6	3.4	12.8	4.1	17.0	5.4	21.3	6.8	31.9	10.1	42.5	13.5
R-448A,R-449A	4.3	1.1	6.5	1.7	8.7	2.3	10.9	2.8	13.0	3.4	17.4	4.5	21.7	5.6	32.6	8.3	43.5	10.9
R-507, R-404A	4.1	1.1	6.1	1.6	8.2	2.1	10.2	2.7	12.2	3.3	16.3	4.1	20.4	5.6	30.6	8.3	40.8	11.8

**NOTES:**

Based on 110°F liquid temperature at bottom of riser.

**Table 6. Recommended Line Sizes for R-404A and R507\***

Capacity BTUH	Suction Line Size																Liquid Line Size			
	Suction Temperature																Receiver to Expansion Valve Equivalent Lengths			
	-10°F				-20°F				-30°F				-40°F							
	Equivalent Lengths				Equivalent Lengths				Equivalent Lengths				Equivalent Lengths							
25'	50'	100'	150'	25'	50'	100'	150'	25'	50'	100'	150'	25'	50'	100'	150'	25'	50'	100'	150'	
78,000	1-3/8	1-5/8	1-5/8	1-5/8	1-5/8	1-5/8	1-5/8	2-1/8	1-5/8	1-5/8	1-5/8	2-1/8	1-5/8	1-5/8	1-5/8	2-1/8	5/8	5/8	5/8	5/8
84,000	1-3/8	1-5/8	1-5/8	2-1/8	1-5/8	1-5/8	2-1/8	2-1/8	1-5/8	1-5/8	2-1/8	2-1/8	1-5/8	1-5/8	2-1/8	2-1/8	5/8	5/8	5/8	7/8
90,000	1-5/8	1-5/8	2-1/8	2-1/8	1-5/8	1-5/8	2-1/8	2-1/8	1-5/8	2-1/8	2-1/8	2-1/8	1-5/8	1-5/8	2-1/8	2-1/8	5/8	5/8	7/8	7/8
120,000	1-5/8	2-1/8	2-1/8	2-5/8	1-5/8	2-1/8	2-1/8	2-5/8	1-5/8	2-1/8	2-1/8	2-5/8	1-5/8	2-1/8	2-1/8	2-5/8	5/8	5/8	7/8	7/8
150,000	2-1/8	2-1/8	2-5/8	2-5/8	2-1/8	2-1/8	2-5/8	2-5/8	2-1/8	2-1/8	2-5/8	2-5/8	2-1/8	2-1/8	2-5/8	2-5/8	5/8	7/8	7/8	7/8
180,000	2-1/8	2-1/8	2-5/8	2-5/8	2-1/8	2-1/8	2-5/8	2-5/8	2-1/8	2-1/8	2-5/8	2-5/8	2-1/8	2-1/8	2-5/8	2-5/8	7/8	7/8	7/8	1-1/8
210,000	2-1/8	2-1/8	2-5/8	3-1/8	2-1/8	2-5/8	2-5/8	3-1/8	2-1/8	2-5/8	2-5/8	3-1/8	2-1/8	2-5/8	2-5/8	3-1/8	7/8	7/8	1-1/8	1-1/8
240,000	2-1/8	2-5/8	2-5/8	3-1/8	2-1/8	2-5/8	2-5/8	3-1/8	2-5/8	2-5/8	3-1/8	3-1/8	2-5/8	2-5/8	3-1/8	3-1/8	7/8	7/8	1-1/8	1-1/8
300,000	2-5/8	2-5/8	3-1/8	3-1/8	2-5/8	2-5/8	3-1/8	3-5/8	2-5/8	2-5/8	3-1/8	3-5/8	2-5/8	2-5/8	3-5/8	3-5/8	7/8	1-1/8	1-1/8	1-3/8
360,000	2-5/8	2-5/8	3-1/8	3-5/8	2-5/8	2-5/8	3-5/8	3-5/8	2-5/8	3-1/8	3-5/8	3-5/8	2-5/8	3-1/8	3-5/8	4-1/8	1-1/8	1-1/8	1-3/8	1-3/8
480,000	2-5/8	3-1/8	3-5/8	3-5/8	2-5/8	3-1/8	3-5/8	3-5/8	3-1/8	3-5/8	4-1/8	4-1/8	3-1/8	3-5/8	4-1/8	4-1/8	1-1/8	1-1/8	1-3/8	1-5/8
600,000	3-1/8	3-1/8	3-5/8	4-1/8	3-1/8	3-1/8	3-5/8	3-5/8	3-1/8	3-5/8	4-1/8	4-1/8	3-1/8	3-5/8	4-1/8	4-1/8	1-1/8	1-3/8	1-5/8	1-5/8

**\* NOTES:**

1. Sizes that are **highlighted** indicate maximum suction line sizes that should be used for risers. Riser size should not exceed horizontal size. Properly placed suction traps must also be used for adequate oil return. All sizes shown are for O.D. Type L copper tubing.
2. Suction line sizes selected at pressure drop equivalent to 2°F. Reduce estimate of system capacity accordingly.
3. If system load drops below 40% of design, consideration to installing double suction risers should be made.

**Table 7. Recommended Suction Line Sizes for R-448A/R-449A\***

Capacity BTUH	Suction Line Length																							
	Suction Temperature																							
	-10°F Equivalent Lengths						-20°F Equivalent Lengths						-30°F Equivalent Lengths						-40°F Equivalent Lengths					
	25'	50'	75'	100'	150'	200'	25'	50'	75'	100'	150'	200'	25'	50'	75'	100'	150'	200'	25'	50'	75'	100'	150'	200'
78,000	1 3/8	1 5/8	1 5/8	1 5/8	1 5/8	2 1/8	1 5/8	1 5/8	1 5/8	1 5/8	2 1/8	2 1/8	1 5/8	1 5/8	1 5/8	1 5/8	2 1/8	2 1/8	1 5/8	1 5/8	1 5/8	1 5/8	2 1/8	2 1/8
84,000	1 3/8	1 5/8	1 5/8	1 5/8	2 1/8	2 1/8	1 5/8	1 5/8	1 5/8	2 1/8	2 1/8	2 1/8	1 5/8	1 5/8	1 5/8	2 1/8	2 1/8	2 1/8	1 5/8	1 5/8	1 5/8	2 1/8	2 1/8	2 1/8
90,000	1 5/8	1 5/8	1 5/8	2 1/8	2 1/8	2 5/8	1 5/8	1 5/8	2 1/8	2 1/8	2 1/8	2 5/8	1 5/8	2 1/8	2 1/8	2 1/8	2 1/8	2 5/8	1 5/8	1 5/8	2 1/8	2 1/8	2 1/8	2 5/8
120,000	1 5/8	2 1/8	2 1/8	2 1/8	2 5/8	2 5/8	1 5/8	2 1/8	2 1/8	2 1/8	2 5/8	2 5/8	1 5/8	2 1/8	2 1/8	2 1/8	2 5/8	2 5/8	1 5/8	2 1/8	2 1/8	2 1/8	2 5/8	2 5/8
150,000	2 1/8	2 1/8	2 1/8	2 5/8	2 5/8	2 5/8	2 1/8	2 1/8	2 1/8	2 5/8	2 5/8	2 5/8	2 1/8	2 1/8	2 1/8	2 5/8	2 5/8	2 5/8	2 1/8	2 1/8	2 5/8	2 5/8	2 5/8	2 5/8
180,000	2 1/8	2 1/8	2 5/8	2 5/8	2 5/8	3 1/8	2 1/8	2 1/8	2 5/8	2 5/8	2 5/8	3 1/8	2 1/8	2 1/8	2 5/8	2 5/8	2 5/8	3 1/8	2 1/8	2 1/8	2 5/8	2 5/8	2 5/8	3 1/8
210,000	2 1/8	2 1/8	2 5/8	2 5/8	3 1/8	3 1/8	2 1/8	2 5/8	2 5/8	2 5/8	3 1/8	3 1/8	2 1/8	2 5/8	2 5/8	2 5/8	3 1/8	3 1/8	2 1/8	2 5/8	2 5/8	2 5/8	3 1/8	3 1/8
240,000	2 1/8	2 5/8	2 5/8	2 5/8	3 1/8	3 1/8	2 1/8	2 5/8	2 5/8	2 5/8	3 1/8	3 1/8	2 5/8	2 5/8	2 5/8	3 1/8	3 1/8	3 5/8	2 5/8	2 5/8	2 5/8	3 1/8	3 1/8	3 5/8
300,000	2 5/8	2 5/8	2 5/8	3 1/8	3 1/8	3 5/8	2 5/8	2 5/8	2 5/8	3 1/8	3 5/8	3 5/8	2 5/8	2 5/8	3 1/8	3 1/8	3 5/8	4 1/8	2 5/8	2 5/8	3 1/8	3 5/8	3 5/8	4 1/8
360,000	2 5/8	2 5/8	3 1/8	3 1/8	3 5/8	3 5/8	2 5/8	2 5/8	3 1/8	3 5/8	3 5/8	4 1/8	2 5/8	3 1/8	3 5/8	3 5/8	3 5/8	4 1/8	2 5/8	3 1/8	3 5/8	3 5/8	4 1/8	4 1/8
480,000	2 5/8	3 1/8	3 1/8	3 5/8	3 5/8	4 1/8	2 5/8	3 1/8	3 1/8	3 5/8	3 5/8	4 1/8	3 1/8	3 5/8	3 5/8	4 1/8	4 1/8	4 1/8	3 1/8	3 5/8	3 5/8	4 1/8	4 1/8	4 1/8
600,000	3 1/8	3 1/8	3 1/8	3 5/8	4 1/8	4 1/8	3 1/8	3 1/8	3 1/8	3 5/8	3 5/8	4 1/8	3 1/8	3 5/8	3 5/8	4 1/8	4 1/8	5 1/8	3 1/8	3 5/8	3 5/8	4 1/8	4 1/8	5 1/8

**\* NOTES**

- Sizes that are highlighted indicate maximum suction line sizes that should be used for risers. Riser size should not exceed horizontal size. Properly placed suction traps must also be used for adequate oil return. All sizes shown are for O.D. Type L copper tubing.
- Suction line sizes selected at pressure drop equivalent to 2°F. Reduce estimate of system capacity accordingly.
- If system load drops below 40% of design, consideration to installing double suction risers should be made.

**Table 9. Recommended Liquid Line Sizes for R-448A/R-449A\***

Capacity BTUH	Liquid Line Length					
	Receiver to Expansion Valve Equivalent Lengths					
	25'	50'	75'	100'	150'	200'
78,000	1/2	1/2	5/8	5/8	5/8	7/8
84,000	1/2	5/8	5/8	5/8	5/8	7/8
90,000	1/2	5/8	5/8	5/8	7/8	7/8
120,000	5/8	5/8	5/8	7/8	7/8	7/8
150,000	5/8	7/8	7/8	7/8	7/8	7/8
180,000	5/8	7/8	7/8	7/8	7/8	1 1/8
210,000	7/8	7/8	7/8	7/8	7/8	1 1/8
240,000	7/8	7/8	7/8	7/8	1 1/8	1 1/8
300,000	7/8	7/8	1 1/8	1 1/8	1 1/8	1 1/8
360,000	7/8	7/8	1 1/8	1 1/8	1 1/8	1 1/8
480,000	1 1/8	1 1/8	1 1/8	1 1/8	1 3/8	1 3/8
600,000	1 1/8	1 1/8	1 1/8	1 3/8	1 3/8	1 3/8

**\* NOTES**

- Sizes that are highlighted indicate maximum suction line sizes that should be used for risers. Riser size should not exceed horizontal size. Properly placed suction traps must also be used for adequate oil return. All sizes shown are for O.D. Type L copper tubing.
- Suction line sizes selected at pressure drop equivalent to 2°F. Reduce estimate of system capacity accordingly.
- If system load drops below 40% of design, consideration to installing double suction risers should be made.

## Evacuation and Leak Detection

Due to the smaller molecule size of HFC's, they will tend to leak more readily than CFC's. Consequently, it is of the utmost importance that proper system evacuation and leak detection procedures be employed.

Manufacturer recommendation is a minimum of 500 micron evacuation. In addition, a vacuum decay test is strongly recommended to assure there is not a large pressure differential between the system and vacuum pump. Good evacuation processes include frequent vacuum pump oil changes and large diameter, short hose connections to both high and low sides of the system preferably using bronze braided hose. Leak detection can be carried out in the conventional manner. If HCFC or CFC tracer gas is used, care must be taken to completely remove all traces of the gas prior to introducing HFC's.

Electronic leak detectors are now available that will sense HFC's. This is considered preferable since it removes the possibility of chlorine remaining in the system after leak testing with HCFC's and/or CFC's. There is a view that even small quantities of chlorine may act as a catalyst encouraging copper plating and/or corrosion and should therefore be avoided.

All service valves and ball valves should be in the opened position.

## Leak Testing

After all lines are connected, the entire system must be leak tested. The complete system should be pressurized to not more than 150 psig with refrigerant and dry nitrogen (or dry CO<sub>2</sub>). The use of an electronic type leak detector is highly recommended because of its greater sensitivity to small leaks. As a further check it is recommended that this pressure be held for a minimum of 12 hours and then rechecked. For a satisfactory installation, the system must be leak tight.

## Line Insulation

After the final leak test, refrigerant lines exposed to high ambient conditions should be insulated to reduce heat pickup and prevent the formation of flash gas in the liquid lines. Suction lines must always be insulated with 3/4" wall Armstrong "Armaflex" or equal. Due to mechanical subcooling of the liquid, it is recommended that liquid lines be insulated with 1/2 wall insulation or better. The insulation located in outdoor environments should be protected from UV exposure to prevent deterioration of insulating value.

**CAUTION:** Do not use the refrigeration compressor to evacuate the system. Do not start the compressor while it is in a vacuum. Unit should be charged with oil before evacuation begins

## Evacuation

A vacuum pump should be connected to both the low and high side evacuation valves with copper tube or high vacuum hoses (1/4" ID minimum). If the compressor has service valves, they should remain closed. A deep vacuum gauge capable of registering pressure in microns should be attached to the system for pressure readings.

A shut off valve between the gauge connection and vacuum pump should be provided to allow the system pressure to be checked after evacuation. Do not turn off vacuum pump when connected to an evacuated system before closing shut off valve. The vacuum pump should be operated until a pressure of 1,500 microns absolute pressure is reached — at which time the vacuum should be broken with the refrigerant to be used in the system through a drier until the system pressure rises above "0" psig.

**NOTE:** Refrigerant used during evacuation cannot be vented. Reclaim all used refrigerant. EPA regulations are constantly being updated. Ensure your procedure follows correct regulations.

### Repeat this operation a second time.

Open the compressor service valves and evacuate the entire system to 500 microns absolute pressure.

The system should be left for 30 minutes and micron level monitored to ensure there is not a significant rise in micron level. A significant rise indicates a leak or moisture trapped in the system.

Once satisfactory, raise the pressure to 2 psig with the refrigerant and remove the vacuum pump.

## Refrigerant Charging Instructions

1. Install a liquid line drier in the refrigerant supply line between the service gauge and the liquid service port of the receiver.
2. This extra drier will insure that all refrigerant supplied to the system is clean and dry.
3. When initially charging a system that is in a vacuum, liquid refrigerant can be added directly into the receiver tank.
4. Condensing unit refrigerant capacity can be held in the receiver. For condenser flooded refrigerant charge, please see Table 2 on page 5.
5. Check equipment catalog for refrigerant capacity. Do not add more refrigerant than the data tag indicates, unless the line run exceeds 25ft. Then, add additional refrigerant as per Table 1 on page 9. Weigh the refrigerant drum before charging so an accurate record can be kept of the weight of refrigerant put in the system.
6. Start the system and finish charging until the sight glass indicates a full charge and the proper amount has been weighed in. If the refrigerant must be added to the system through the suction side of the compressor, charge in vapor form only. Liquid charging must be done in the high side only or with liquid metering devices to protect the compressor.

**WARNING:** All wiring must be done in accordance with applicable codes and local ordinances.

## Field Wiring

The field wiring should enter the areas as provided on the unit. The wiring diagram for each unit is located on the inside of the electrical panel door. All field wiring should be done in a professional manner and in accordance with all governing codes. Before operating unit, double check all wiring connections, including the factory terminals.

Factory connections can vibrate loose during shipment.

1. The serial data tag on the unit is marked with the electrical characteristic for wiring the unit.
2. Consult the wiring diagram in the unit cooler and in the condensing unit for proper connections.
3. Wire type should be of copper conductor only and of the proper size to handle the connected load.
4. The unit must be grounded.

## C450 System Controls and Adjustment

The system 450 series provide on/off and proportional control of temperature and pressure conditions. For these condensing units, these controls will provide control of the following functions: On/Off Relay output control for low pressure cut in/out, high pressure cut in/out, loaders solenoid cut in/out, and condenser fan cut in/out. For optional compressor VFD and/or modulating condenser fan control, a proportional analog output will be provided.

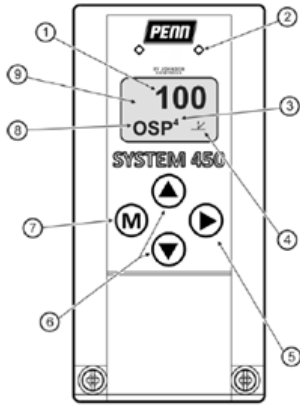

Callout	Feature	Description
1	Status or Setup Value	Displays the current input status, output status or setup parameter value for the displayed input sensor, output and/or setup parameter. Press up or down to select a different parameter value when the value is flashing. (Here, 100 = 100%.)
2	LED	Green LEDs on the Control Module and Expansion Modules indicate if the associated relay or analog output is on or off. If the analog output is partially on (between 0–10V), the LED blinks. The higher the output signal strength, the longer the LED is on.
3	Output Number	Displays a numerical value that identifies the output associated with the status or setup value shown on the screen. Output numbers are automatically determined by the outputs' physical positions (left to right) in the module assembly. (Here, 4 = Output 4.)
4	Control Ram Icon	Displays whether an analog output (only) is set as direct-acting or reverse-acting, and whether the output signal strength is at minimum or maximum when the sensed property is at Setpoint. The control ramp icon displayed is determined by the output's SP, EP, OSP, and OEP setup values.
5	Next Button	In the Main screens, press right arrow to scroll through the system status screens. In a setup screen, press right arrow to save the (flashing) setup value and go to the next setup screen
6	Up and Down Buttons	Press up or down to select a different value for any flashing value in the setup value field. In the Main (sensor status) screens, press up and down hold both and for 5 seconds to access the setup Start screens.

Callout	Feature	Description
7	Menu Button	Press "M" to move through the sensor and output setup start screens. When moving through the status or setup screens, press "M" to return to the status start screen or setup start screen.
8	Status or Setup Identifier	Displays the unit of measurement, output, sensor number, or setup parameter for the displayed status or setup value. (Here, the setup identifier OSP represents % output signal strength at setpoint).
9	LCD	Backlit LCD screen. The LCD brightness is adjustable. During normal operation, the LCD displays the Main screens.

## System 450 Wiring Terminals

Terminal Block Type	Terminal Label	Terminal Function
Sensor and Low-Voltage Supply Power Terminal Block	24V	Provides power terminal for active 24VAC humidity sensors when a C450YNN power module is connected.
	5V	Provides 5 VDC power for active sensors.
	Sn1, Sn2, Sn3	Accepts passive or active input signals from sensors.
	C	Provides low-voltage common connections for passive or active sensors connected to the 5V, Sn1, Sn2, and Sn3 terminals. <b>Note: The terminals are connected internally.</b>
	COM	Provides low-voltage common connections for 24 VAC power connected to the 5V, Sn1, Sn2, and Sn3 terminals. <b>Note: The terminals are connected internally.</b>
Line-Voltage Output Relay Terminal Blocks (on Control and Expansion Modules with Relay Output)	LNC1, LNC2	Connects equipment control circuit to the line-voltage Normally Closed (LNC) contact on the SPDT relay. LNC2 terminals are only on control and expansion modules with two output relays.
	LNO1, LNO2	Connects equipment control circuit to the line-voltage Normally Open (LNO) contact on the SPDT relay. LNO2 terminals are only on control and expansion modules with two output relays.
	LC1, LC2	Connects line power to the line-voltage Common (LC) on the SPDT relay. LC2 terminals are only on control and expansion modules with two output relays.



## System 450 Wiring Terminals (CONTINUED)

Terminal Block Type	Terminal Label	Terminal Function
Low-Voltage Analog Output terminal Block (on Control and Expansion Modules with Analog Outputs)	A01 A02	In conjunction with the COM terminal, provides a self-detecting analog output signal; either 0 to 10 VDC or 4 to 20 mA.
	ACOM	In conjunction with the A01 or A02 terminal, provides a self-detecting analog output signal; either 0 to 10 VDC or 4 to 20 mA.

## Troubleshooting System 450 Controls

System 450 control modules display error messages on the LCD when the module detects a sensor, sensor wiring, sensor power, or power supply failure. The table immediately below shows the System 450 error messages that may be displayed, and provides possible causes for the error messages and the solutions for remedying the errors.

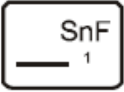
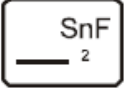
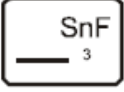
Error Screen	Problem/Symptom	Possible Cause	Solution
  	<p>Sensor failure is detected and &lt; SNF &gt; is displayed (instead of a value). Outputs that reference the failed sensor are operating in the Sensor Failure Modes selected for the Output at setup.</p>	<p>Sensor, sensor wiring, or sensor connections may have failed to open or close.</p>	<p>Check and verify integrity of sensor wiring and connections. Measure the voltage between the sensor terminal (Sn1, Sn2, or Sn3) and the low voltage common (C) terminal (with the sensor connected). See Table 11 for the sensor's expected voltage range. If the sensor wiring and sensor connections are good, replace the sensor and recheck the voltage.</p>

## Specified Voltage Ranges Between Sensor Terminals

Connected Sensor	Specified Voltage Range Measured between a Sensor terminal (Sn1, Sn2, or Sn3) and a Common Terminal (C)
A99B temperature Sensor	0.49 to 1.43 VDC
P499 electronic Pressure Transducer	0 to 5.0 VDC

## Check Out and Start Up

1. After the installation has been completed, the following points should be covered before the system is placed in operation:
2. Check all electrical and refrigerant connections. Be sure they are all tight.
3. Check compressor mounting fasteners for tightness.
4. Wiring diagrams, instruction bulletins, etc., attached to the condensing units should be read and filed for future reference.
5. All fan motors should be checked for proper rotation. Fan motor mounts and fan blades should be carefully checked for tightness and proper alignment.
6. Electric evaporator fan motors should be temporarily wired for continuous operation until the room temperature has stabilized.
7. Observe system pressures during charging and initial operation. Do not add oil while the system is short of refrigerant unless oil level is dangerously low.
8. Ensure oil level is within sight glass of oil separator and heaters have been run 24 hours prior to startup.
9. Check that compressor and oil separator shut off valves are opened.
10. Subcooler solenoid valve energizes when compressor is loaded at least 75%. The expansion valve metering refrigerant into the heat exchanger should be set immediately to prevent liquid refrigerant from returning to compressor through the ECO port. Ensure compressor not flooded with oil (can occur if oil injection solenoid is energized when compressor not operating). Do not start compressor when initially running unit without a set of gauges attached to the suction and discharge ports of compressor. At initial compressor start, the following changes in pressure should be observed: suction pressure drops and discharge pressure rises. **\*\*If not observed, stop unit immediately. Compressor running with reverse rotation will lead to failure within seconds!**
11. Ensure pressure switches cutout above 0 PSIG. Monitor system pressures to ensure pressure switches cut-in and out as set. Set switches so that compressor does not run into a vacuum
12. Continue charging until system has sufficient refrigerant for proper operation. Do not overcharge. Topping off the system during the initial pull-down can contribute to overfilling system. Remember that bubbles in a sight glass may be caused by a restriction as well as a shortage of refrigerant.
13. Do not leave unit unattended until the system has reached normal operating conditions and the oil charge has been properly adjusted to maintain the oil within lower sight glass range.
14. Make sure all Schrader valve caps are in place and tight.
15. Make sure ALL service valves are properly back-seated and tighten valve packing if necessary.

**CAUTION:** Check phase rotation with phase meter prior to first start. Warranty will be denied if damage is a result of reverse rotation. Extreme care must be taken in starting compressors for the first time after system charging. At this time, most of the refrigerant might be in the oil separator creating a condition which could cause compressor damage due to improper lubrication from refrigerant return in oil injection line. Activating the oil separator heater 24 hours prior to start-up is required.

## Operational Check Out

After the system has been charged and has operated for at least two hours at normal operating conditions without any indication of malfunction, it should be allowed to operate overnight on automatic controls. Then a thorough recheck of the entire system operation should be made as follows:

1. Check compressor discharge and suction pressures. If not within system design limits, determine why and take corrective action.
2. Check liquid line sight glass and expansion valve operation. If there are indications that more refrigerant is required, leak test all connections and system components and repair any leaks before adding refrigerant.
3. Observe oil level in oil separator sight glass. Add oil as within lower sight glass range.
4. Thermostatic expansion valves must be checked for proper superheat settings. Feeler bulbs must be in positive contact with the suction line and should be insulated. Valves set at high superheat will lower refrigeration capacity. Low superheat promotes liquid slugging and compressor bearing washout.
5. Using suitable instruments, carefully check line voltage and amperage at the compressor terminals. Voltage must be within 10% of that indicated on the condensing unit nameplate. If high or low voltage is indicated, notify the power company. If amperage draw is excessive, immediately determine the cause and take corrective action. On three phase motor compressors, check to see that a balanced load is drawn by each phase.
6. The maximum approved settings for high pressure controls on our air cooled condensing equipment is 425 psig. On air cooled systems, check as follows:  
Disconnect the fan motors or block the condenser inlet air. Watch high pressure gauge for cutout point. Recheck all safety and operating controls for proper operation and adjust if necessary.
7. Check evaporator drain pan for proper drainage.
8. Maximum oil is within sight glass range of oil separator
9. Oil cooler max setting is 150°F outlet temperature
10. Check pressure and temperature of Economizer port vapor line. Adjust heat exchanger expansion valve as necessary.
11. Check winter head pressure controls for pressure setting.
12. Install instruction card and control system diagram for use of building manager or owner.

**IMPORTANT:** In order to obtain the maximum capacity from a system, and to ensure trouble-free operation, it is necessary to balance each and every system.

## System Balancing - Compressor Superheat

This is extremely important with any refrigeration system. The critical value which must be checked is suction superheat.

Suction superheat should be checked **at the compressor** as follows:

1. Measure the suction temperature of the suction line about one foot back from the compressor using an accurate thermometer.
2. Subtract the saturated temperature from the actual suction line temperature. The difference is superheat.

Too low a suction superheat can result in liquid being returned to the compressor. This will cause dilution of the oil and eventual failure of the bearings.

Too high a suction superheat will result in excessive discharge temperatures which cause a break down of the oil and results in wear, and damage.

It should also be remembered that the system capacity decreases as the suction superheat increases. For maximum system capacity, suction superheat should be kept as low as is practical. Bitzer recommends a minimum of 5°F superheat at the compressor. We recommend that the superheat **at the compressor** be between 5°F and 15°F.

If adjustments to the suction superheat need to be made, the expansion valve at the evaporator should be adjusted.

**NOTE: All adjustable controls and valves must be field adjusted to meet desired operation. There are no factory preset controls or valve adjustments. This includes low pressure, high pressure, adjustable head pressure systems and expansion valves.**

## General Sequence of Operation

### Refrigeration Cycle

1. Power is supplied to the timer at terminals "1" and "N".
2. The fan delay and the defrost termination thermostat is closed in the fan delay position and open in the defrost termination position. The unit cooler fans run continuously.
3. The defrost heaters are off.
4. The room thermostat closes when the temperature rises above the desired setting.
5. The liquid line solenoid is energized and opens, which allows liquid refrigerant to flow through the unit cooler.
6. The low pressure control closes when the suction pressure rises above the cutin setting of the control.
7. The oil flow switch safety control is closed. If the oil flow switch does not close in 3 seconds, the oil safety opens, thus breaking the circuit to the compressor contactor holding coil. The compressor will not operate. This control is reset manually and must be reset before the compressor can be restarted.
8. The compressor contactor closes. The compressor and condenser fan start simultaneously. The room temperature gradually decreases to the desired temperature.
9. Once the desired temperature is reached, the thermostat opens and the liquid line solenoid closes, stopping refrigerant flow through the evaporator.
10. Suction pressure decreases and the compressor contactor opens when the pressure drops below the cutout setting on the low pressure control. The compressor and condenser fan stop running.
11. This cycle is repeated as many times as necessary to satisfy the room thermostat.
12. Frost starts to form on the evaporator coil and continues to form until the defrost cycle is initiated.

### Defrost Cycle

1. The defrost cycle starts automatically by the timer at predetermined times. Typical settings are two to four defrost cycles per day for freezers. For heavier frost loads additional settings may be required.
2. Switch "2" to "4" opens in the timer which breaks the circuit to the room thermostat, liquid line solenoid, and evaporator fan motors, allowing the compressor to pump down and shut off. Simultaneously switch "1" to "3" closes in the timer allowing current to flow to one side of the defrost heater contactor. When the compressor shuts off, an auxiliary contact will send power to the contactor holding coil; thus, energizing the defrost heaters.
3. The heaters raise the temperature of the coil to 32°F causing the frost to melt off the coil.
4. When the coil warms to 45°F to 55°F, the defrost termination thermostat closes, which allows current to the switching solenoid in the timer allowing the refrigeration cycle to begin again.
5. The evaporator heaters are off. If the termination thermostat fails to close, the fail-safe set on the timer will terminate defrost.
6. The low pressure control closes and the compressor will start.
7. When the coil temperature reaches 23°F to 30°F, the fan delay closes. This allows the current to flow to the fan motors. The fan motors start running.
8. The system will now operate in the refrigeration cycle until another defrost period is initiated by the timer.

### Electric Defrost Troubleshooting

The electric defrost units are relatively simple and trouble-free in operation:

**Table 11. System Troubleshooting Guide**

PROBLEM	POSSIBLE CAUSES	POSSIBLE CORRECTIVE STEPS
Compressor will not run	<ol style="list-style-type: none"> <li>1. Main switch open.</li> <li>2. Fuse blown.</li> <li>3. Thermal overloads tripped.</li> <li>4. Defective contactor or coil.</li> <li>5. System shut down by safety devices.</li> <li>6. No cooling required.</li> <li>7. Liquid line solenoid will not open.</li> <li>8. Motor electrical trouble.</li> <li>9. Loose wiring.</li> <li>10. Phase loss monitor inoperative.</li> <li>11. Flow switch open.</li> <li>12. Oil filter differential too high</li> </ol>	<ol style="list-style-type: none"> <li>1. Close switch.</li> <li>2. Check electrical circuits and motor winding for shorts or grounds. Investigate for possible overloading. Replace fuse after fault is corrected.</li> <li>3. Overloads are automatically reset. Check unit closely when unit comes back on line.</li> <li>4. Repair or replace.</li> <li>5. Determine type and cause of shutdown and correct it before resetting safety switch.</li> <li>6. None. Wait until calls for cooling.</li> <li>7. Repair or replace coil.</li> <li>8. Check motor for open windings, short circuit or burn out.</li> <li>9. Check all wire junctions. Tighten all terminal screws.</li> <li>10. Reset compressor circuit. If oil not returning, check oil level and differential pressure between suction/discharge.</li> <li>11. Change filter.</li> </ol>
Compressor noisy or vibrating	<ol style="list-style-type: none"> <li>1. Flooding of refrigerant into compressor.</li> <li>2. Improper piping support on suction or liquid line. Worn compressor.</li> </ol>	<ol style="list-style-type: none"> <li>1. Check setting of expansion valves.</li> <li>2. Relocate, add or remove hangers.</li> <li>3. Replace.</li> </ol>
High discharge pressure	<ol style="list-style-type: none"> <li>1. Non-condensables in system.</li> <li>2. System overcharges with refrigerant.</li> <li>3. Discharge shutoff valve partially closed.</li> <li>4. Fan not running.</li> <li>5. Head pressure control setting.</li> <li>6. Dirty condenser coil.</li> </ol>	<ol style="list-style-type: none"> <li>1. Remove the non-condensables.</li> <li>2. Remove excess.</li> <li>3. Open valve.</li> <li>4. Check electrical circuit.</li> <li>5. Adjust.</li> <li>6. Clean.</li> </ol>
Low discharge pressure	<ol style="list-style-type: none"> <li>1. Faulty condenser temperature regulation.</li> <li>2. Suction shutoff valve partially closed.</li> <li>3. Insufficient refrigerant in system.</li> <li>4. Low suction pressure.</li> <li>5. Variable head pressure valve.</li> </ol>	<ol style="list-style-type: none"> <li>1. Check condenser control operation.</li> <li>2. Open valve.</li> <li>3. Check for leaks. Repair and add charge.</li> <li>4. See corrective steps for low suction pressure.</li> <li>5. Check valve setting.</li> </ol>
High suction pressure	<ol style="list-style-type: none"> <li>1. Excessive load.</li> <li>2. Expansion valve overfeeding.</li> </ol>	<ol style="list-style-type: none"> <li>1. Reduce load or add additional equipment.</li> <li>2. Check remote bulb. Regulate superheat.</li> </ol>
Low suction pressure	<ol style="list-style-type: none"> <li>1. Lack of refrigerant.</li> <li>2. Evaporator dirty or iced.</li> <li>3. Clogged liquid line filter drier.</li> <li>4. Clogged suction line or compressor suction gas strainers.</li> <li>5. Expansion valve malfunctioning.</li> <li>6. Condensing temperature too low.</li> <li>7. Improper TXV.</li> </ol>	<ol style="list-style-type: none"> <li>1. Check for leaks. Repair and add charge.</li> <li>2. Clean.</li> <li>3. Replace cartridge(s).</li> <li>4. Clean strainers.</li> <li>5. Check and reset for proper superheat.</li> <li>6. Check means for regulating condensing temperature.</li> <li>7. Check for proper sizing.</li> </ol>
Compressor loses oil	<ol style="list-style-type: none"> <li>1. Lack of refrigerant.</li> <li>2. Refrigerant flood back.</li> <li>3. Improper piping or traps.</li> <li>4. Three way valve opened fully to oil cooler.</li> </ol>	<ol style="list-style-type: none"> <li>1. Check for leaks and repair. Add refrigerant.</li> <li>2. Maintain proper superheat at compressor.</li> <li>3. Correct piping.</li> <li>4. Not enough oil in oil cooler to return to compressor.</li> </ol>
Compressor electronic protector switch open	<ol style="list-style-type: none"> <li>1. Operating beyond design conditions.</li> <li>2. Dirty condenser coil.</li> <li>3. Overcharged system.</li> </ol>	<ol style="list-style-type: none"> <li>1. Add components to bring conditions within acceptable limits (i.e., CPR/EPR valves, additional condenser surface, liquid injection, etc.).</li> <li>2. Open valve.</li> <li>3. Clean coil.</li> <li>4. Reduce charge.</li> </ol>
Oil temperature too high	<ol style="list-style-type: none"> <li>1. Suction superheat too high</li> <li>2. Dirty oil cooler coil</li> <li>3. Fans not running</li> </ol>	<ol style="list-style-type: none"> <li>1. Adjust superheat at expansion valves so that it is within acceptable range.</li> <li>2. Clean coil</li> <li>3. Check electrical circuit</li> </ol>

## Preventive Maintenance Guidelines

### Unit Coolers

At every six month interval, or sooner if local conditions cause clogging or fouling of air passages through the finned surface, the following items should be checked.

#### 1. Visually inspect unit

- Look for signs of corrosion on fins, cabinet, copper tubing and solder joints.
- Look for excessive or unusual vibration for fan blades or sheet metal panels when in operation. Identify fan cell(s) causing vibration and check motor and blade carefully.
- Look for oil stains on headers, return bends, and coil fins. Check any suspect areas with an electronic leak detector.
- Check drain pan to insure that drain is clear of debris, obstructions or ice buildup and is free draining.

#### 2. Clean evaporator coil and blades

- Periodic cleaning can be accomplished by using a brush, pressurized water or a commercially available evaporator coil cleaner or mild detergent. Never use an acid based cleaner. Follow label directions for appropriate use. Be sure the product you use is approved for use in your particular application.
- Flush and rinse coil until no residue remains.
- Pay close attention to drain pan, drain line and trap.

#### 3. Check the operation of all fans and ensure airflow is unobstructed

- Check that each fan rotates freely and quietly. Replace any fan motor that does not rotate smoothly or makes an unusual noise.
- Check all fan set screws and tighten if needed.
- Check all fan blades for signs of stress or wear. Replace any blades that are worn, cracked or bent.
- Verify that all fan motors are securely fastened to the motor rail.
- Lubricate motors if applicable.

#### 4. Inspect electrical wiring and components

- Visually inspect all wiring for wear, kinks, bare areas and discoloration. Replace any wiring found to be damaged.
- Verify that all electrical and ground connections are secure, tighten if necessary.
- Check operation/calibration of all fan cycle and defrost controls when used.
- Look for abnormal accumulation of ice patterns and adjust defrost cycles accordingly
- Compare actual defrost heater amp draw against unit data plate.
- Visually inspect heaters to ensure even surface contact with the coil. If heaters have crept, decrease defrost termination temperature and be sure you have even coil frost patterns. Re-align heaters as needed.
- Check drain line heat tape for proper operation (supplied and installed by others).

#### 5. Refrigeration Cycle

- Check unit cooler superheat and compare reading for your specific application
- Visually inspect coil for even distribution

### Air-Cooled Condensing Units/Quarterly

#### 1. Visually inspect unit

- Look for signs of oil stains on interconnection piping and condenser coil. Pay close attention to areas around solder joints, building penetrations and pipe clamps. Check any suspect areas with an electronic leak detector. Repair any leaks found and add refrigerant as needed.
- Check condition of moisture indicator/sightglass in the sight glass if so equipped. Replace liquid line drier if there is indication of slight presence of moisture. Replace refrigerant, oil and drier if moisture concentration is indicated to be high.
- Check moisture indicator/sightglass for flash gas. If found check entire system for refrigerant leaks and add refrigerant as needed after repairing any leaks.
- Check compressor sightglass (if equipped) for proper oil level.
- Check condition of condenser. Look for accumulation of dirt and debris

(clean as required).

- Check for unusual noise or vibration. Take corrective action as required.
- Inspect wiring for signs of wear or discoloration and repair if needed.
- Check and tighten all flare connections.

### Air-Cooled Condensing Units/Semi-Annually

#### 2. Repeat all quarterly inspection items.

#### 3. Clean condenser coil and blades

- Periodic cleaning can be accomplished by using a brush, pressurized water and a commercially available foam coil cleaner. If foam cleaner is used, it should not be an acid based cleaner. Follow label directions for appropriate use.
- Rinse until no residue remains.

#### 4. Check operation of condenser fans

- Check that each fan rotates freely and quietly. Replace any fan motor that does not rotate smoothly or makes excessive noise.
- Check all fan blade set screws and tighten as required.
- Check all fan blades for signs of cracks, wear or stress. Pay close attention to the hub and spider. Replace blades as required.
- Verify that all motors are mounted securely.
- Lubricate motors if applicable. Do not lubricate permanently sealed, ball bearing motors.

#### 5. Inspect electrical wiring and components

- Verify that all electrical and ground connections are secure, tighten as required.
- Check condition of compressor and heater contractors. Look for discoloration and pitting. Replace as required.
- Clean electrical cabinet. Look for signs of moisture, dirt, debris, insects and wildlife. Take corrective action as required.
- Verify operation of oil sump heater by measuring amp draw.

#### 6. Check refrigeration cycle

- Check suction, discharge pressure readings. If abnormal take appropriate action.
- Check pressure drop across all filters and driers. Replace as required.
- Verify that superheat at the compressor conforms to specification. (5°F to 15°F)
- Check pressure and safety control settings and verify proper operation.

### Air-Cooled Condensing Units/Annually

#### 7. In addition to quarterly and semiannual maintenance checks, submit an oil sample for analysis

- Look for high concentrations of acid or moisture. Change oil and driers until test results read normal.
- Investigate source of high metal concentrations, which normally are due to abnormal bearing wear. Look for liquid refrigerant in the crankcase, low oil pressure or low superheat as a possible source.

#### 8. Inspect suction accumulator (if equipped)

- If the accumulator is insulated remove insulation and inspect for leaks and corrosion.
- Pay close attention to all copper to steel brazed connections
- Wire brush all corroded areas and peeling paint.
- Apply an anticorrosion primer and paint as required. Re-insulate if applicable.



# Wiring Diagrams - Typical

## WITHOUT DEFROST - COMPRESSOR POWER

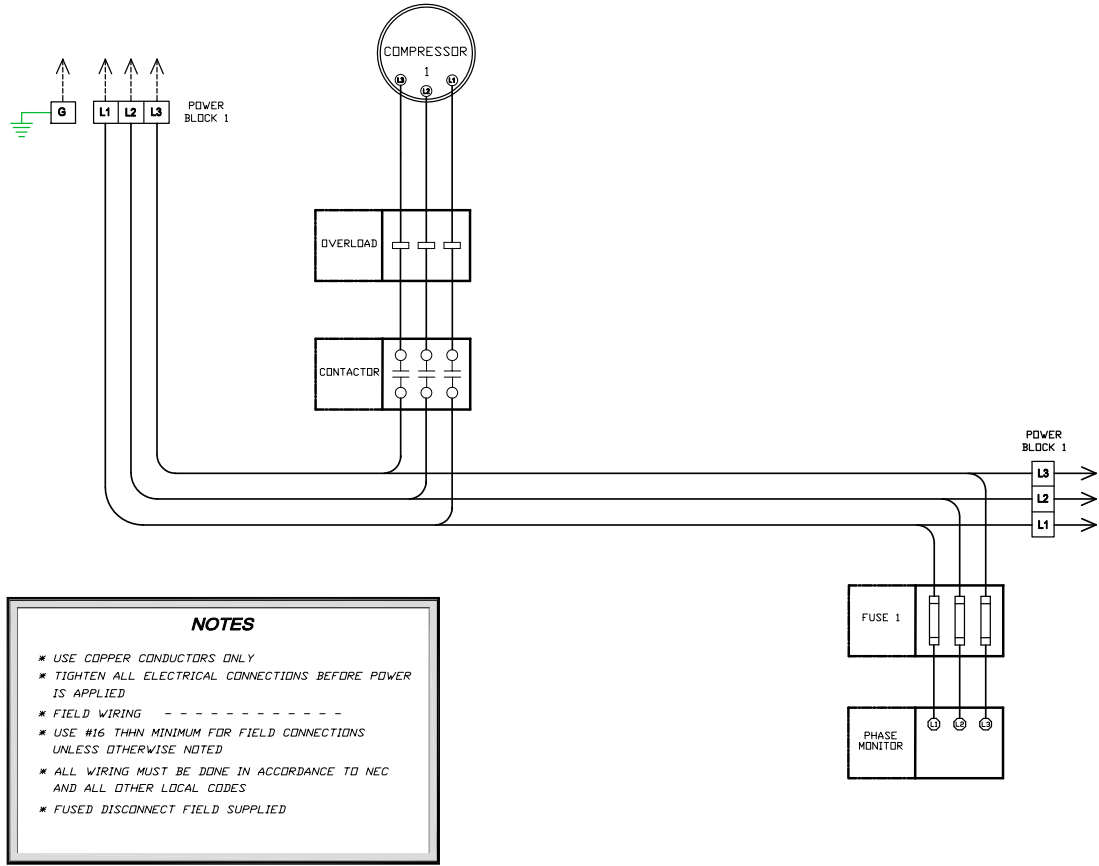

## WITHOUT DEFROST - CONDENSER/OIL COOLER FAN POWER

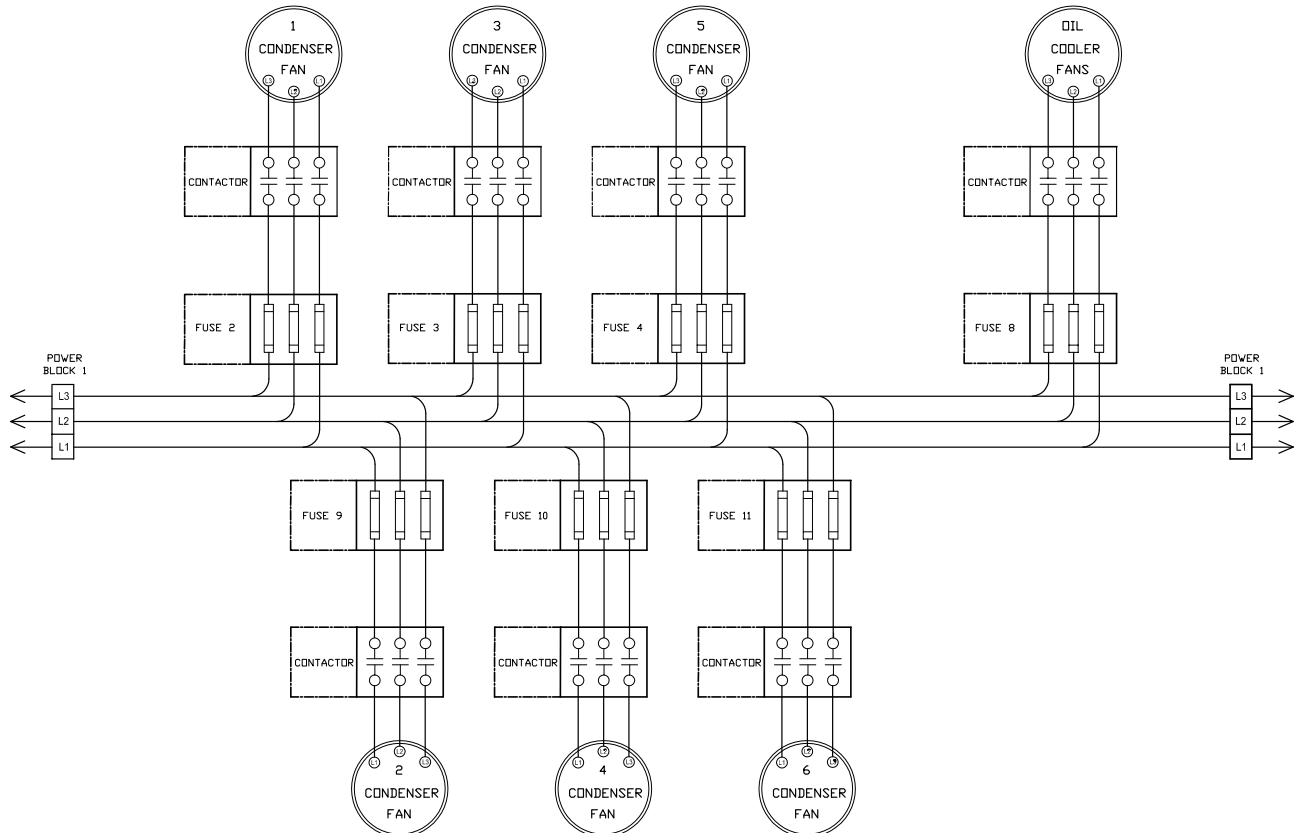

# Wiring Diagrams - Typical

## WITHOUT DEFROST - CONTROL POWER

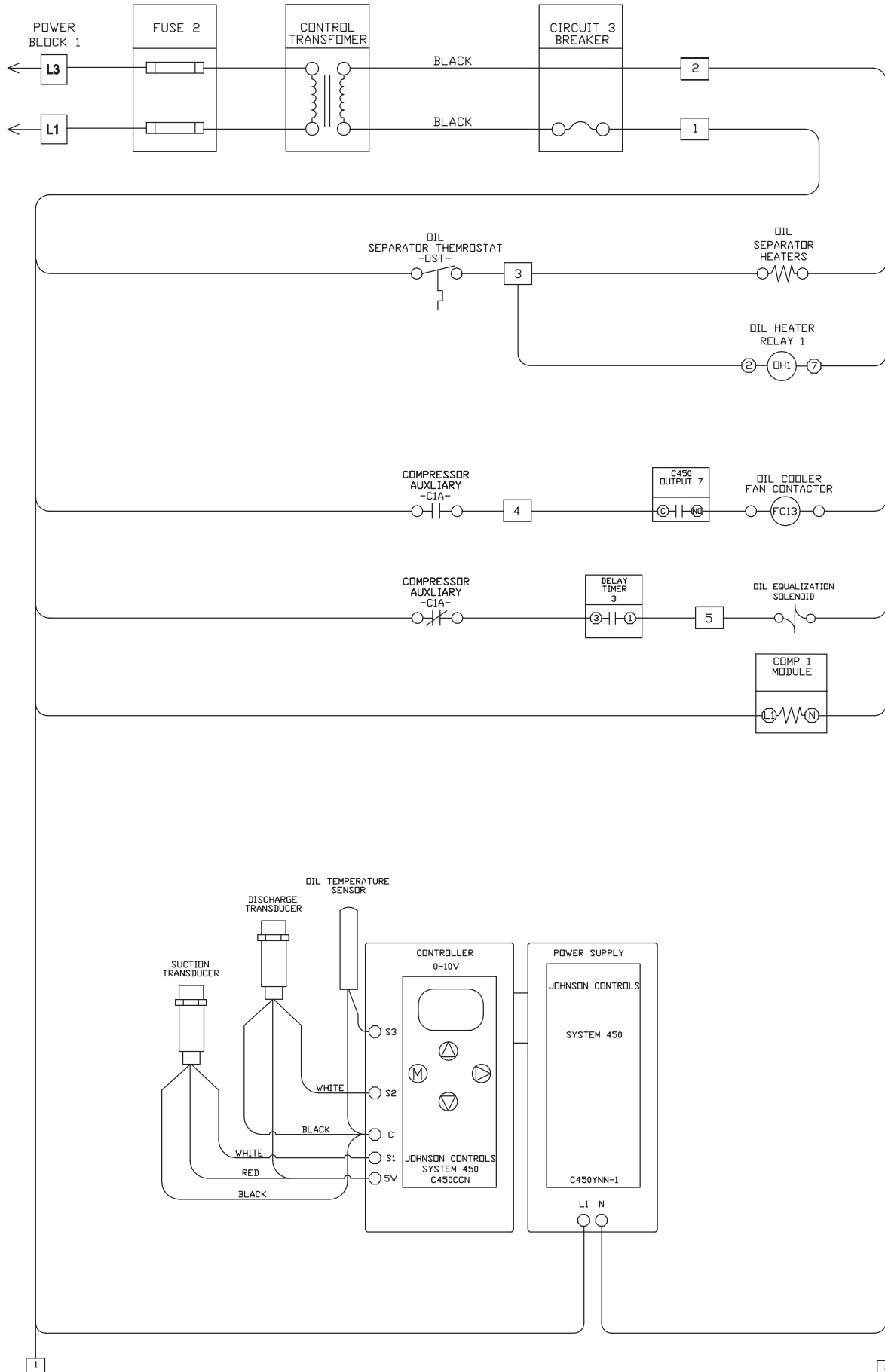

# Wiring Diagrams - Typical

## WITHOUT DEFROST - COMPRESSOR CIRCUIT

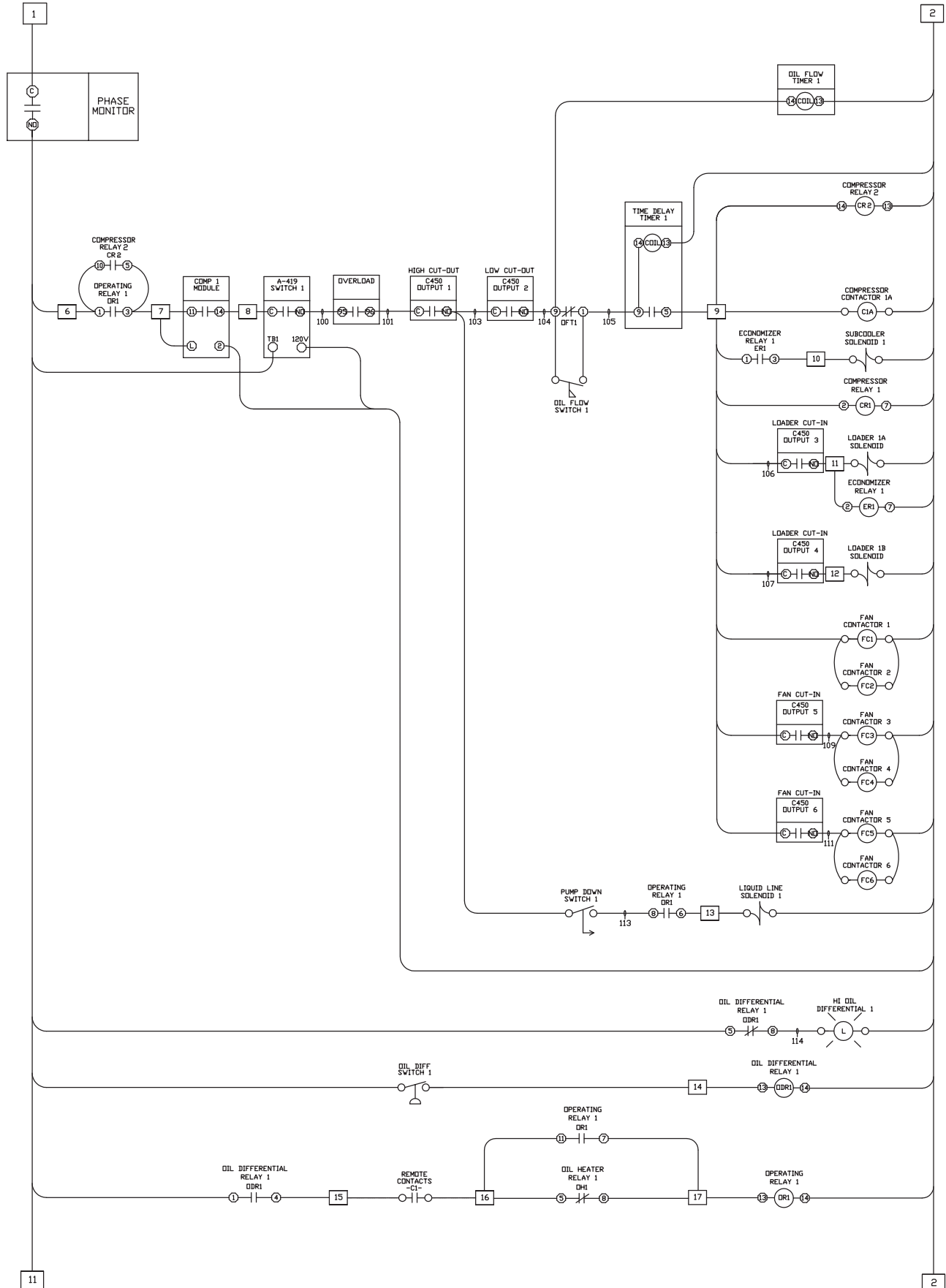

# Wiring Diagrams - Typical

## WITH DEFROST - COMPRESSOR POWER

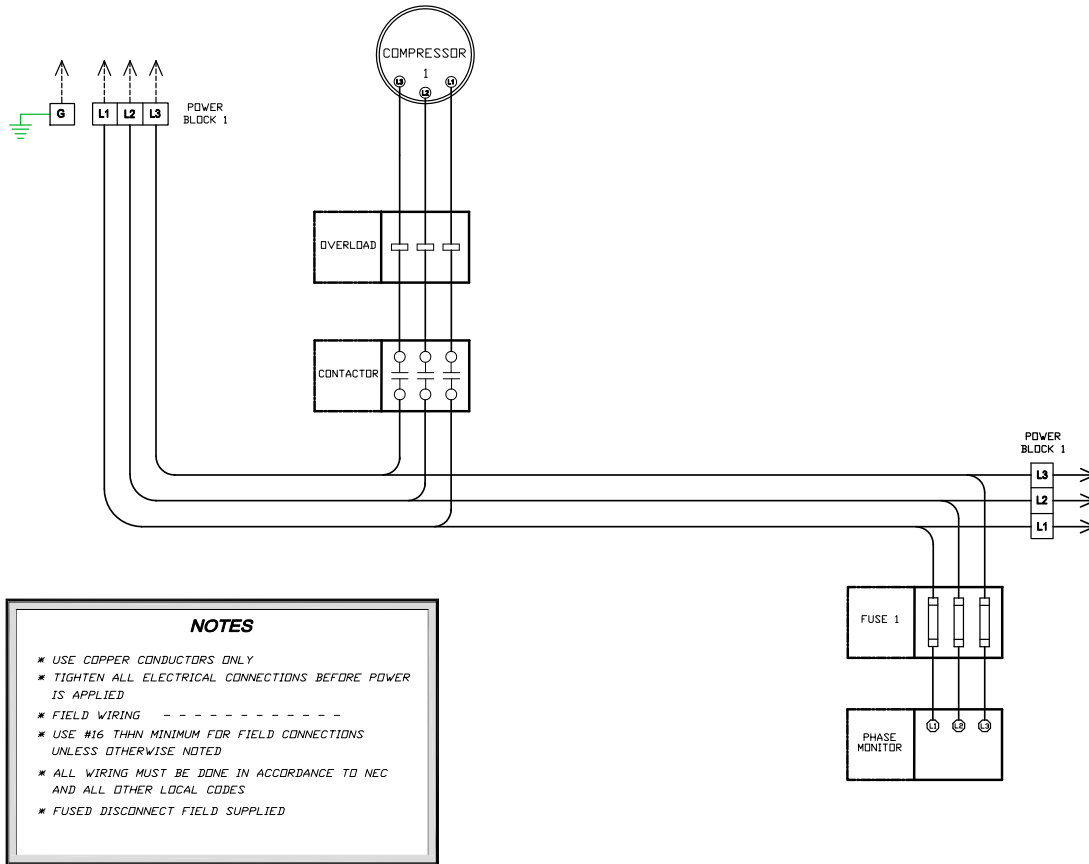

## WIRING WITH DEFROST - CONDENSER/OIL COOLER FAN POWER

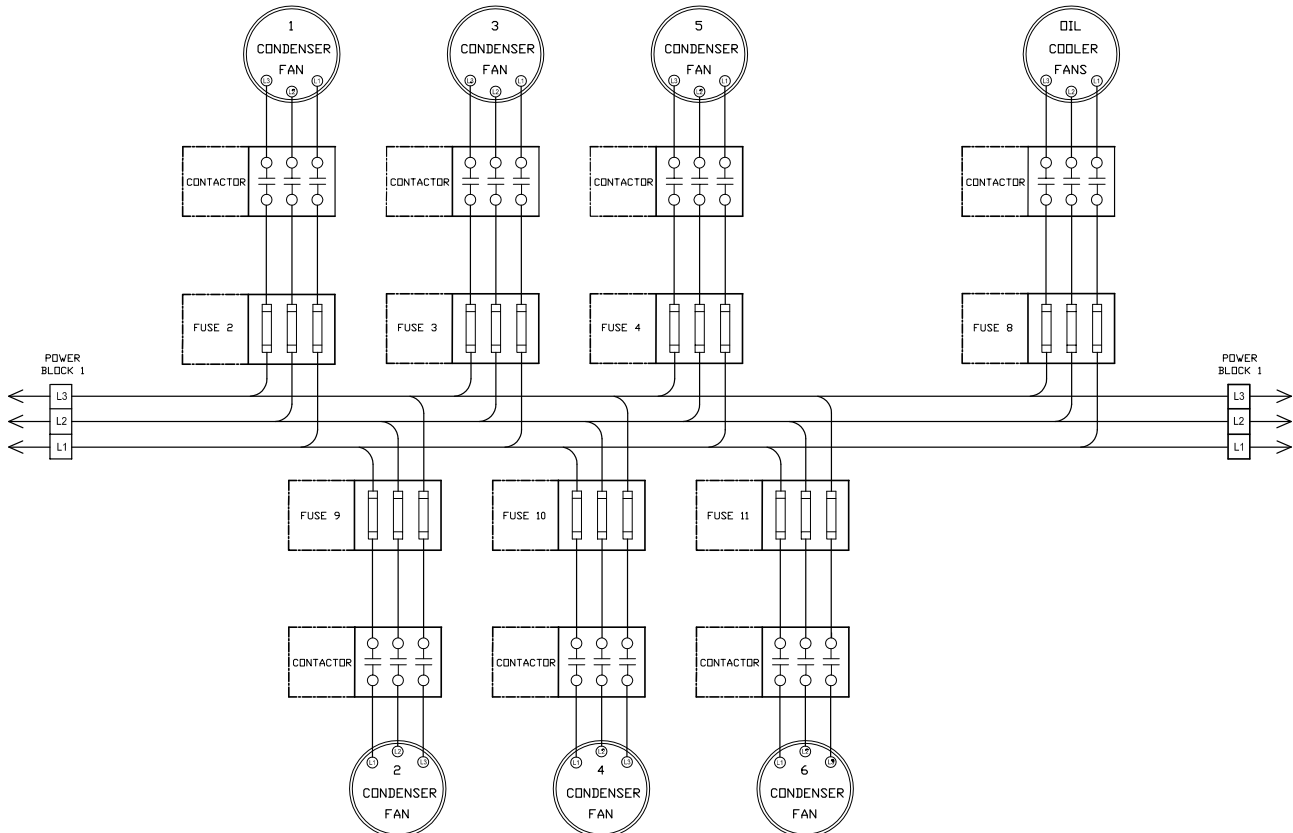

# Wiring Diagrams - Typical

## WITH DEFROST - EVAPORATOR/DEFROST HEATER POWER

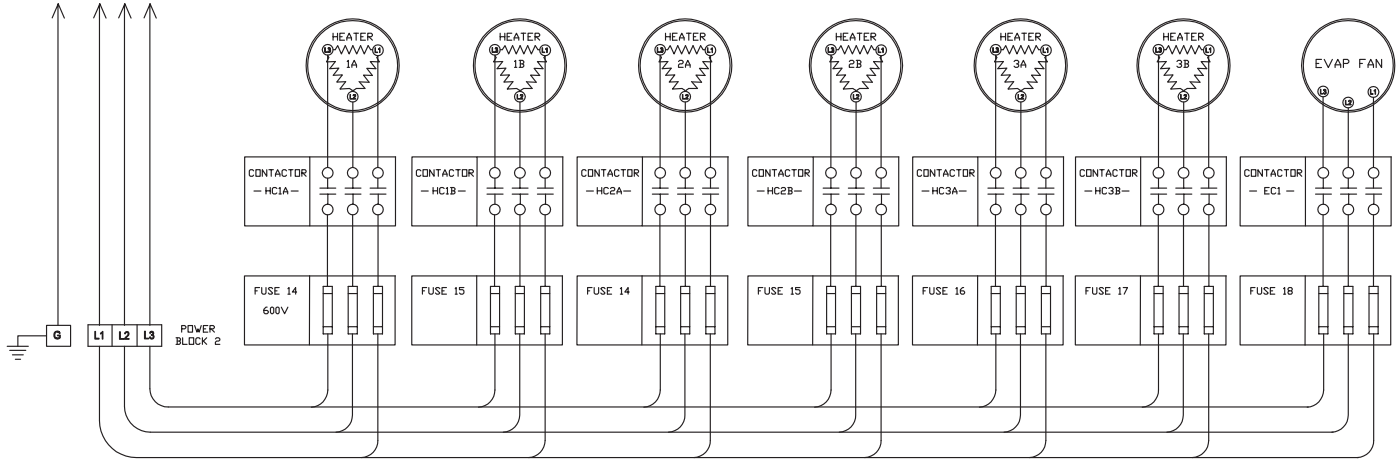



# Wiring Diagrams - Typical

## WITH DEFROST - CONTROL POWER

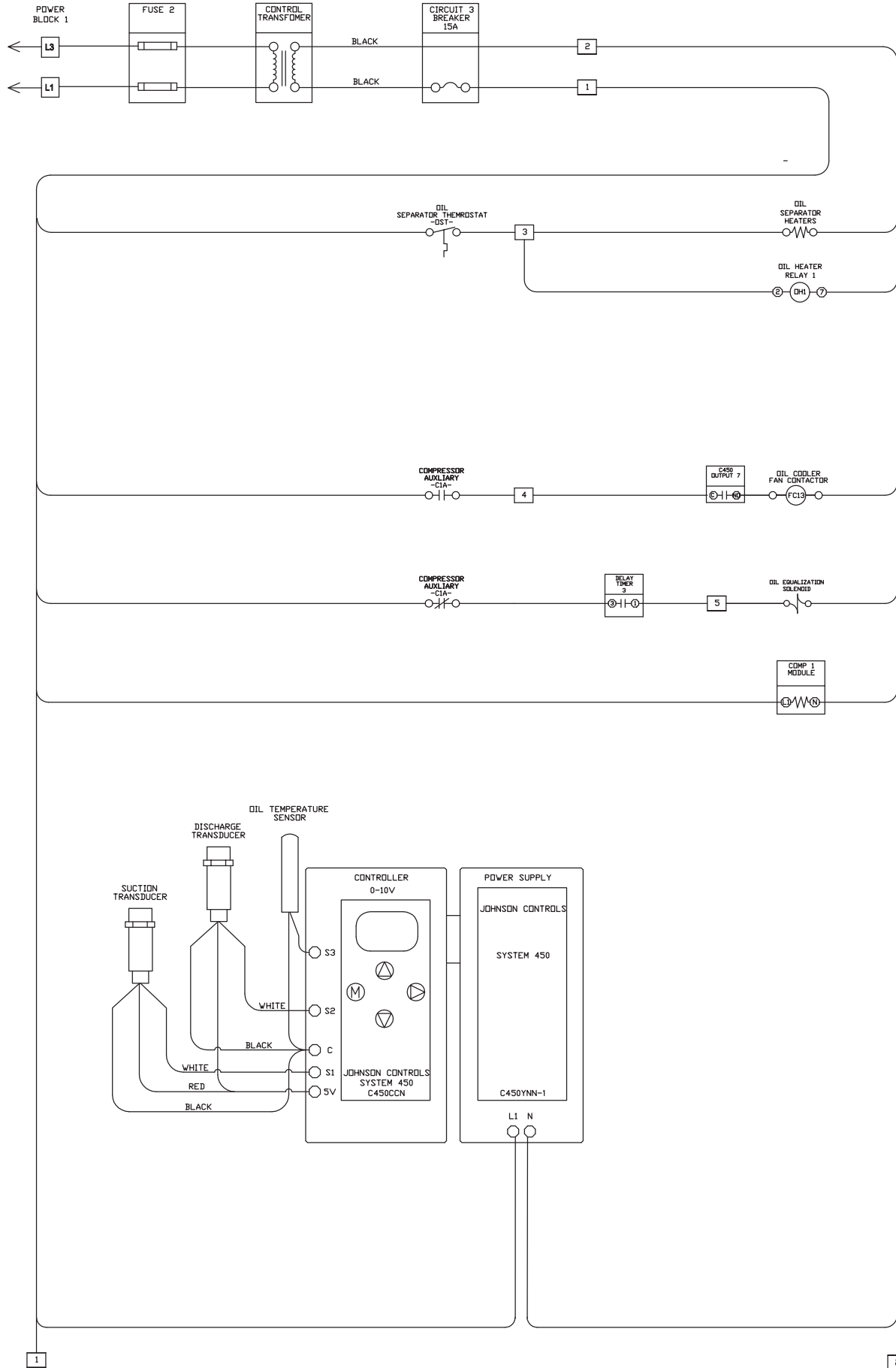

# Wiring Diagrams- Typical

## WITH DEFROST - COMPRESSOR CIRCUIT

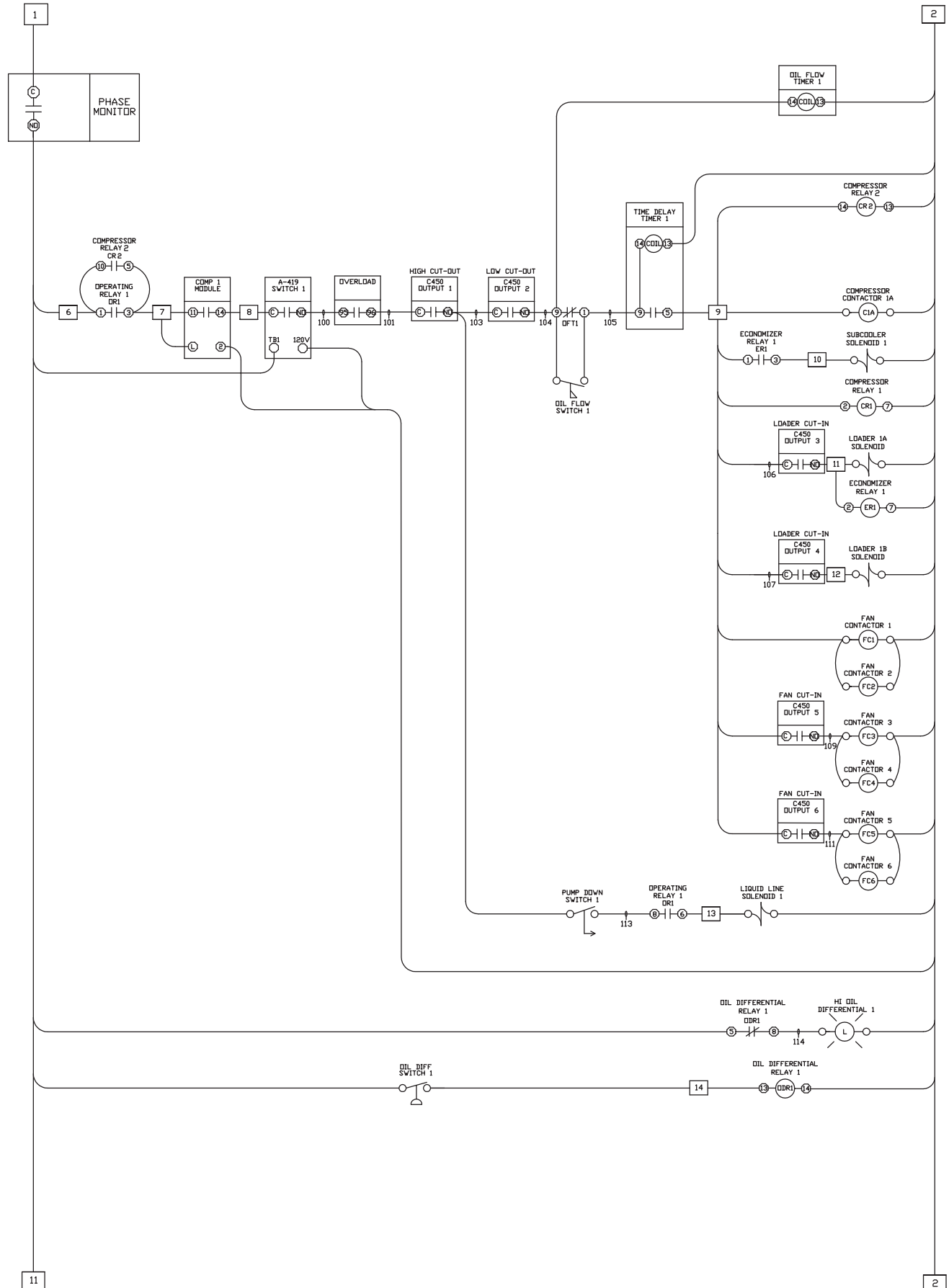

# Wiring Diagrams - Typical

## WITH DEFROST - DEFROST CONTROL

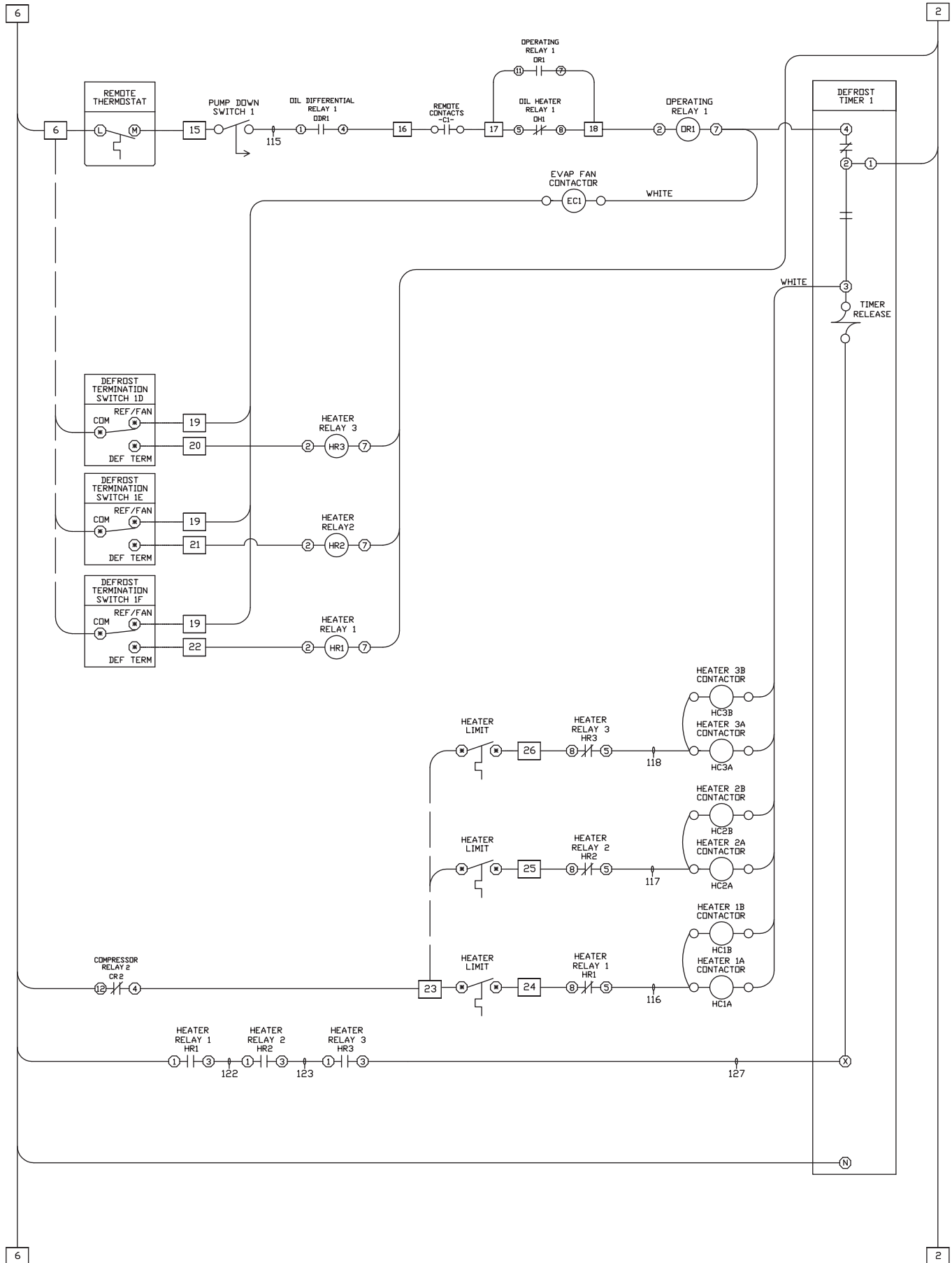









## Replacement Parts by



InterLink™ Commercial Refrigeration Parts is your link to a complete line of dependable and certified commercial refrigeration parts, accessories and innovative electronic controls for all Heatcraft Refrigeration Products (HRP) brands - including Bohn, Larkin, Climate Control and Chandler. At InterLink, we provide our wholesalers with a comprehensive selection of product solutions and innovative technologies for the installed customer base. And every product is built to ensure the same high performance standards with which all HRP brands are built — backed by a dedicated team to serve every customer need, delivering at the best lead times in the industry.

Replacement parts should be obtained from your local InterLink wholesaler. Replacement parts, which are covered under the terms of the "Warranty Statement" section on page 2 of this manual, will be reimbursed for total part cost only. The original invoice from the parts supplier must accompany all warranty claims for replacement part reimbursement. Heatcraft Refrigeration Products reserves the right to adjust the compensation amount paid on any parts submitted for warranty reimbursement when a parts supplier's original invoice is not provided with a claim. **For more information, call 800-686-7278 or visit [www.heatcraftprd.com](http://www.heatcraftprd.com)**

Electrical	
TIMER DELAY ON MAKE ADJ 0-10MIN 120V	22599092
SENSOR TEMPERATURE A99BC-300C	28901201
POWER SUPPLY C450YNN-1 POWER MODULE	28950100
CONTROL C450CCN-3C CONTROL MODULE	28950101
CONTROL C450SPN-1C EXPANSION	28950102
TRANSDUCER P499RAP-105K 0-500PSIG	28950103
P499RAP-102C TRANSDUCER 0-200PSIG	28950104
CONTROL C450SCN-3C EXPANSION MODULE	28950106
THERMOSTAT A421 ELECTRONIC -120/240VAC	28963201

Mechanical	
OIL FILTER BITZER HS COMPRESSOR	26399026
OIL FLOW SWITCH HS64/74	28999050

Condenser Parts	
Fan Motor, 1.5 HP	25316401
Fan Blade, 30" Diameter	22900401
Fan Guard, 30" Diameter	23105701

**Replacement compressors  
Call 1-800-GO BITZER  
(24/7 Support)**

**For our complete Refrigeration Systems Installation and Operations Manual (H-IM-64L),  
please visit [www.heatcraftprd.com](http://www.heatcraftprd.com)**

Since product improvement is a continuing effort, we reserve the right to make changes in specifications without notice.

The name behind the brands you trust.™

