



Low Velocity Center Mount Unit Coolers

Technical Guide

Models HWA | HWE | HWG

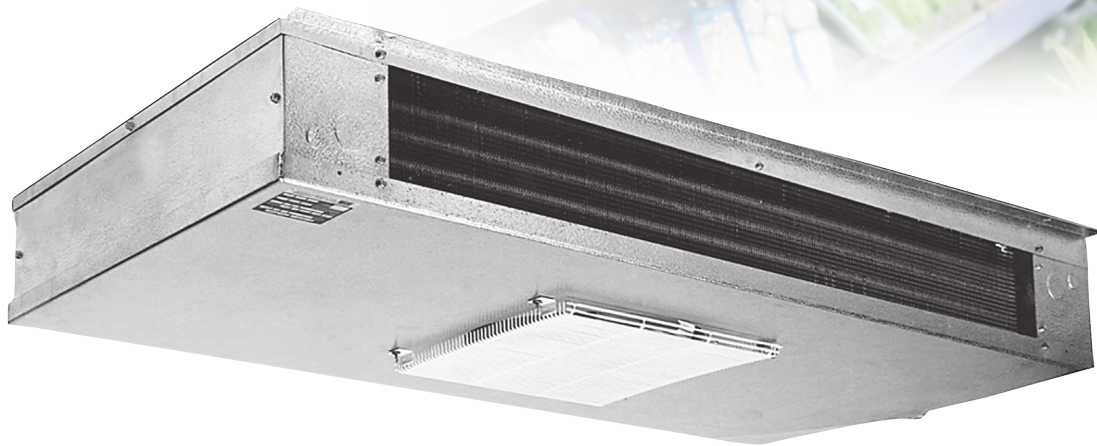

Table of Contents

Nomenclature.....	2
Features & Benefits.....	3
Performance Data	
All Defrost Types.....	4-9
Specifications	
Air Defrost	4-5
Electric Defrost	6-7
Hot Gas.....	8-9
Dimensional Data	10
Replacement Parts by InterLink™.....	10
Physical Data.....	11
Standard Nozzle Selection.....	11



Choose the most energy-efficient motor available for evaporators.



The EC motor is an energy efficient option on Chandler Low Velocity Center Mount Unit Coolers. Available on all new equipment or as an easy-to-install, drop-in replacement aftermarket part from InterLink™ Commercial Refrigeration Parts. Because they are a drop-in replacement for existing shaded pole and PSC motors, installation is quick and easy. It's a high impact, quick payback solution for reducing costs and achieving green initiatives without replacing the entire system.

EC motors by InterLink are up to 75% energy efficient - that's a 51-59% increase over shaded pole motors and a 30-35% increase over permanent-split capacitor (PSC) motors. With all of this added efficiency, you can count on more energy savings and lower operational costs while taking a step in the right direction toward conserving our planet's resources.

Nomenclature

HW	100	A	G	C
Model Series	Capacity	Electrical Code	Control Option	Design Revision
HWA= Larkin Low Velocity Center Mount, air defrost	# BTUH x 100 (R-404A)	A = 115/1/60	G = intelliGen™	
HWE= Larkin Low Velocity Center Mount, electric defrost		B = 208-230/1/60		
HWG= Larkin Low Velocity Center Mount, hot gas defrost		M = 460/1/60		
		AE = 115/1/60 (EC)		
		BE = 208-230/1/60 (EC)		

Features & Benefits

Cabinet

- Low height makes it ideal for low ceiling coolers - larger models are only 15 inches tall, allowing for maximum headroom and more product storage
- Unit designed to be mounted flush against the ceiling or suspended on rods
- Heavy gauge grained aluminum cabinet cleans easily and looks attractive
- Stainless steel screws prevent rust streaks
- Liquid line solenoid wire harness is factory-installed for quick installation
- Wire fan guards with PVC coating for durability
- All electrical components factory wired to terminal board and identified, making it easy to field wire the unit
- Cabinet design features access panels on each end for easy access to electrical and refrigeration components
- Fan panel is lightweight and can easily be lowered for easy servicing and installation
- Expansion valve mounts inside the cabinet

Coil

- Sweat connections to reduce potential for leaks
- Coils are dehydrated and sealed at the factory
- Internally enhanced tubing and fin design for higher efficiency
- Electric defrost models incorporate high quality tubular heaters and a standard fixed defrost termination thermostat
- Hot gas defrost models come with a shipped-loose adjustable fan delay and defrost termination thermostat

Drain Pan

- Double drain pan eliminates drain pan sweating

Motors

- Motor rail is design for maximum strength and durability
- Motors are life lubricated and thermal overload protected
- EC Motors available factory-installed or as a drop-in replacement through InterLink™ Commercial Refrigeration Parts in 115/1/60, 208-230/1/60
- PSC Motors are available in 460/1/60 for air and electric defrost

Controls Options

- IntelliGen™ Refrigeration Controller (IRC) units come with factory mounted, tested and calibrated with an electronic expansion valve, pressure transducer, temperature sensors, control board and User Interface. Standard features include Door Sensor, Product Load Input and Alarm Output.
- Optional Field installable IntelliGen Webserver Card (iWC) enables local and remote monitoring on any Phone, Tablet or PC.
- Optional Field installable IntelliGen Integration Card (iIC) enables connectivity to BACnet and Modbus.
- Quick Response Controller units come factory mounted with an electronic expansion valve, pressure transducer, temperature sensors and control board.
- Beacon II™ units come factory mounted with an electronic expansion valve, pressure transducer, temperature sensors and control board.

Other Options

- Factory installed mounted components are available in these configurations:
 - Pre-assembled units come with mounted TXV, liquid line solenoid valve and room thermostat
 - Pre-charged units come with mounted TXV, liquid line solenoid valve, room thermostat, and quick connect fittings
 - Mounted TXV
 - Mounted TXV and solenoid valve
 - Mounted room thermostat
- Most models available with glycol circuiting (see glycol product brochure)
- Units available with stainless steel housing and drain pan
- Units available with copper fins. Air defrost units available with polyester coated fins, or various coil coating options

PERFORMANCE DATA

Model HWA Air Defrost | 60 Hz

Model	Capacity								Fan Data		
	R-404A				R-407A/C/F, R-448A/R-449A				No.	CFM	m ³ h
	10°F TD 25°F SST	6°C TD -4°C SST	15°F TD 25°F SST	8°C TD -4°C SST	10°F TD 25°F SST	6°C TD -4°C SST	15°F TD 25°F SST	8°C TD -4°C SST			
	BTUH	Watts	BTUH	Watts	BTUH	Watts	BTUH	Watts			
HWA050	5,000	1,460	7,500	2,200	5,800	1,700	8,700	2,550	1	725	1,233
HWA075	7,500	2,200	11,250	3,300	8,400	2,460	12,600	3,690	1	730	1,241
HWA100	10,000	2,930	15,000	4,390	11,600	3,400	17,400	5,100	2	1,450	2,465
HWA130	13,000	3,810	19,500	5,710	14,300	4,190	21,450	6,285	2	1,470	2,499
HWA155	15,500	4,540	23,250	6,810	17,360	5,100	26,040	7,650	2	1,460	2,482
HWA180	18,000	5,270	27,000	7,910	20,880	6,120	31,320	9,180	3	2,130	3,621
HWA210	21,000	6,150	31,500	9,230	23,940	7,020	35,910	10,530	4	2,840	4,828
HWA270	27,000	7,910	40,500	11,860	31,860	9,340	47,790	14,010	4	2,800	4,760
HWA340	34,000	9,960	51,000	14,940	40,120	11,760	60,180	17,640	5	3,500	5,950

Model HWA Air Defrost | 50 Hz[†]

Model	Capacity								Fan Data		
	R-404A				R-407A/C/F, R-448A/R-449A				No.	CFM	m ³ h
	10°F TD 25°F SST	6°C TD -4°C SST	15°F TD 25°F SST	8°C TD -4°C SST	10°F TD 25°F SST	6°C TD -4°C SST	15°F TD 25°F SST	8°C TD -4°C SST			
	BTUH	Watts	BTUH	Watts	BTUH	Watts	BTUH	Watts			
HWA050	4,750	1,390	7,130	2,090	5,510	1,610	8,265	2,415	1	660	1,122
HWA075	7,130	2,090	10,690	3,140	7,980	2,340	11,970	3,510	1	660	1,122
HWA100	9,500	2,780	14,300	4,170	11,020	3,230	16,530	4,845	2	1,310	2,227
HWA130	12,350	3,620	18,530	5,420	13,590	3,980	20,385	5,970	2	1,330	2,261
HWA155	14,730	4,310	22,090	6,470	16,490	4,850	24,735	7,275	2	1,320	2,244
HWA180	17,100	5,010	25,650	7,510	19,840	5,810	29,760	8,715	3	1,920	3,264
HWA210	19,950	5,840	29,930	8,770	22,740	6,670	34,110	10,005	4	2,560	4,352
HWA270	25,650	7,510	38,480	11,270	30,270	8,870	45,405	13,305	4	2,530	4,301
HWA340	32,300	9,460	48,450	14,190	38,110	11,170	57,165	16,755	5	3,160	5,372

[†] For EC motors, use 60 Hz capacity and airflow values (Units with EC motors operating at 50 Hz will not see a reduction in performance due to the electronic control of the motor)

SPECIFICATIONS

Model HWA Air Defrost | 60 Hz

Model	PSC Motor						EC Motor			
	115/1/60		230/1/60		460/1/60		115/1/60		230/1/60	
	Amps	Watts	Amps	Watts	Amps	Watts	Amps	Watts	Amps	Watts
HWA050	0.9	90	0.5	90	0.4	117	0.9	55	0.5	55
HWA075	0.9	90	0.5	90	0.4	117	0.9	55	0.5	55
HWA100	1.8	180	1.0	180	0.8	234	1.8	110	1.0	110
HWA130	1.8	180	1.0	180	0.8	234	1.8	110	1.0	110
HWA155	1.8	180	1.0	180	0.8	234	1.8	110	1.0	110
HWA180	2.7	270	1.5	270	1.2	351	2.7	165	1.5	165
HWA210	3.6	360	2.0	360	1.6	468	3.6	220	2.0	220
HWA270	3.6	360	2.0	360	1.6	468	3.6	220	2.0	220
HWA340	4.5	450	2.5	450	2.0	585	4.5	275	2.5	275

Model HWA Air Defrost | 50 Hz

Model	PSC Motor				EC Motor			
	110/1/50		220/1/50		110/1/50		220/1/50	
	Amps	Watts	Amps	Watts	Amps	Watts	Amps	Watts
HWA050	0.8	80	0.4	80	0.9	55	0.5	55
HWA075	0.8	80	0.4	80	0.9	55	0.5	55
HWA100	1.7	160	0.8	160	1.8	110	1.0	110
HWA130	1.7	160	0.8	160	1.8	110	1.0	110
HWA155	1.7	160	0.8	160	1.8	110	1.0	110
HWA180	2.5	240	1.2	240	2.7	165	1.5	165
HWA210	3.3	320	1.6	320	3.6	220	2.0	220
HWA270	3.3	320	1.6	320	3.6	220	2.0	220
HWA340	4.2	400	2.0	400	4.5	275	2.5	275

PERFORMANCE DATA

Model HWE Electric Defrost | 60 Hz

Model	Capacity								Fan Data		
	R-404A				R-407A/C/F, R-448A/R-449A				No.	CFM	m ³ h
	10°F TD 25°F SST	6°C TD -4°C SST	15°F TD 25°F SST	8°C TD -4°C SST	10°F TD 25°F SST	6°C TD -4°C SST	15°F TD 25°F SST	8°C TD -4°C SST			
	BTUH	Watts	BTUH	Watts	BTUH	Watts	BTUH	Watts			
HWE050	5,000	1,460	7,500	2,200	5,800	1,700	8,700	2,550	1	725	1,233
HWE075	7,500	2,200	11,250	3,300	8,400	2,460	12,600	3,690	1	730	1,241
HWE100	10,000	2,930	15,000	4,390	11,600	3,400	17,400	5,100	2	1,450	2,465
HWE130	13,000	3,810	19,500	5,710	14,300	4,190	21,450	6,285	2	1,470	2,499
HWE155	15,500	4,540	23,250	6,810	17,360	5,100	26,040	7,650	2	1,460	2,482
HWE180	18,000	5,270	27,000	7,910	20,880	6,120	31,320	9,180	3	2,130	3,621
HWE210	21,000	6,150	31,500	9,230	23,940	7,020	35,910	10,530	4	2,840	4,828
HWE270	27,000	7,910	40,500	11,860	31,860	9,340	47,790	14,010	4	2,800	4,760
HWE340	34,000	9,960	51,000	14,940	40,120	11,760	60,180	17,640	5	3,500	5,950

Model HWE Electric Defrost | 50 Hz[†]

Model	Capacity								Fan Data		
	R-404A				R-407A/C/F, R-448A/R-449A				No.	CFM	m ³ h
	10°F TD 25°F SST	6°C TD -4°C SST	15°F TD 25°F SST	8°C TD -4°C SST	10°F TD 25°F SST	6°C TD -4°C SST	15°F TD 25°F SST	8°C TD -4°C SST			
	BTUH	Watts	BTUH	Watts	BTUH	Watts	BTUH	Watts			
HWE050	4,750	1,390	7,130	2,090	5,510	1,610	8,265	2,415	1	660	1,122
HWE075	7,130	2,090	10,690	3,140	7,980	2,340	11,970	3,510	1	660	1,122
HWE100	9,500	2,780	14,300	4,170	11,020	3,230	16,530	4,845	2	1,310	2,227
HWE130	12,350	3,620	18,530	5,420	13,590	3,980	20,385	5,970	2	1,330	2,261
HWE155	14,730	4,310	22,090	6,470	16,490	4,850	24,735	7,275	2	1,320	2,244
HWE180	17,100	5,010	25,650	7,510	19,840	5,810	29,760	8,715	3	1,920	3,264
HWE210	19,950	5,840	29,930	8,770	22,740	6,670	34,110	10,005	4	2,560	4,352
HWE270	25,650	7,510	38,480	11,270	30,270	8,870	45,405	13,305	4	2,530	4,301
HWE340	32,300	9,460	48,450	14,190	38,110	11,170	57,165	16,755	5	3,160	5,372

[†] For EC motors, use 60 Hz capacity and airflow values (Units with EC motors operating at 50 Hz will not see a reduction in performance due to the electronic control of the motor)

SPECIFICATIONS

Model HWE Electric Defrost | 60 Hz

Model	PSC Motor				EC Motor		Watts	Defrost Heaters	
	230/1/60		460/1/60		230/1/60			230/1/60	460/1/60
	Amps	Watts	Amps	Watts	Amps	Watts	Total Amps		
HWE050	0.5	90	0.4	117	0.5	55	2,000	8.7	4.4
HWE075	0.5	90	0.4	117	0.5	55	2,400	10.5	5.3
HWE100	1.0	180	0.8	234	1.0	110	2,800	12.2	6.1
HWE130	1.0	180	0.8	234	1.0	110	4,000	17.4	8.7
HWE155	1.0	180	0.8	234	1.0	110	4,000	17.4	8.7
HWE180	1.5	270	1.2	351	1.5	165	4,000	17.4	8.7
HWE210	2.0	360	1.6	468	2.0	220	5,200	22.6	11.3
HWE270	2.0	360	1.6	468	2.0	220	5,200	22.6	11.3
HWE340	2.5	450	2.0	585	2.5	275	7,000	30.4	15.2

Model HWE Electric Defrost | 50 Hz

Model	PSC Motor		EC Motor		Watts	230/1/60 Total Amps
	22/1/50		220/1/50			
	Amps	Watts	Amps	Watts		
HWE050	0.4	80	0.5	55	1,830	8.3
HWE075	0.4	80	0.5	55	2,200	10.0
HWE100	0.8	160	1.0	110	2,560	11.6
HWE130	0.8	160	1.0	110	3,660	16.6
HWE155	0.8	160	1.0	110	3,660	16.6
HWE180	1.2	240	1.5	165	3,660	16.6
HWE210	1.6	320	2.0	220	4,760	21.6
HWE270	1.6	320	2.0	220	4,760	21.6
HWE340	2.0	400	2.5	275	6,400	29.1

PERFORMANCE DATA

Model HWG Hot Gas Defrost | 60 Hz

Model	Capacity								Fan Data		
	R-404A				R-407A/C/F, R-448A/R-449A				No.	CFM	m ³ h
	10°F TD 25°F SST	6°C TD -4°C SST	15°F TD 25°F SST	8°C TD -4°C SST	10°F TD 25°F SST	6°C TD -4°C SST	15°F TD 25°F SST	8°C TD -4°C SST			
	BTUH	Watts	BTUH	Watts	BTUH	Watts	BTUH	Watts			
HWG100	10,000	2,930	15,000	4,390	11,600	3,400	17,400	5,100	2	1,450	2,465
HWG130	13,000	3,810	19,500	5,710	14,300	4,190	21,450	6,285	2	1,470	2,499
HWG155	15,500	4,540	23,250	6,810	17,360	5,100	26,040	7,650	2	1,460	2,482
HWG180	18,000	5,270	27,000	7,910	20,880	6,120	31,320	9,180	3	2,130	3,621
HWG210	21,000	6,150	31,500	9,230	23,940	7,020	35,910	10,530	4	2,840	4,828
HWG270	27,000	7,910	40,500	11,860	31,860	9,340	47,790	14,010	4	2,800	4,760
HWG340	34,000	9,960	51,000	14,940	40,120	11,760	60,180	17,640	5	3,500	5,950

Model HWG Hot Gas Defrost | 50 Hz[†]

Model	Capacity								Fan Data		
	R-404A				R-407A/C/F, R-448A/R-449A				No.	CFM	m ³ h
	10°F TD 25°F SST	6°C TD -4°C SST	15°F TD 25°F SST	8°C TD -4°C SST	10°F TD 25°F SST	6°C TD -4°C SST	15°F TD 25°F SST	8°C TD -4°C SST			
	BTUH	Watts	BTUH	Watts	BTUH	Watts	BTUH	Watts			
HWG100	9,500	2,780	1,430	4,170	11,020	3,230	16,530	4,845	2	1,310	2,227
HWG130	12,350	3,620	18,530	5,420	13,590	3,980	20,385	5,970	2	1,330	2,261
HWG155	14,730	4,310	22,090	6,470	16,490	4,850	24,735	7,275	2	1,320	2,244
HWG180	17,100	5,010	25,650	7,510	19,840	5,810	29,760	8,715	3	1,920	3,264
HWG210	19,950	5,840	29,930	8,770	22,740	6,670	34,110	10,005	4	2,560	4,352
HWG270	25,650	7,510	38,480	11,270	30,270	8,870	45,405	13,305	4	2,530	4,301
HWG340	32,300	9,460	48,450	14,190	38,110	11,170	57,165	16,755	5	3,160	5,372

[†] For EC motors, use 60 Hz capacity and airflow values (Units with EC motors operating at 50 Hz will not see a reduction in performance due to the electronic control of the motor)

Optional Liquid Line Bypass Kit For Hot Gas Defrost

The HWG may be field piped for hot gas defrost using the optional bypass kit.

When compressor vapor, in reverse cycle defrosting, is directed back into the evaporator at the suction connection, it condenses into liquid. The field-installed liquid line bypass kit directs the condensed liquid around the thermostatic expansion valve and back into the liquid line.

Bypass kits include bypass piping, check valve and instructions. Adjustable fan control is shipped loose with hot gas units.

TXV Bypass Kits (Hot Gas Only)

Models Used On	TXV Bypass Kits	
	Type SQE, SBF, or HFESC	Type S
	Part Number	Part Number
HWG100	89897801	89898001
HWG130 - HWG270	89897802	89898002
HWG340	89897803	89898003

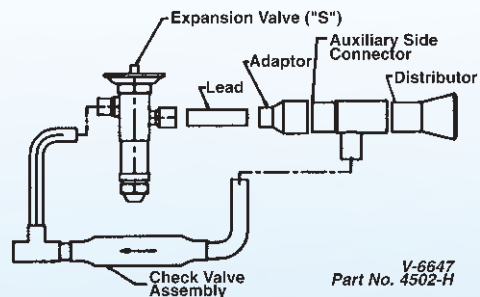

SPECIFICATIONS

Model HWG Hot Gas Defrost | 60 Hz

Model	PSC Motor				EC Motor				Drain Pan Heaters		
	230/1/60		460/1/60		115/1/60		230/1/60		Watts	115/1/60	230/1/60
	Amps	Watts	Amps	Watts	Amps	Watts	Amps	Watts		Total Amps	
HWG100	1.8	180	1.0	180	1.8	110	1.0	110	350	3.0	1.5
HWG130	1.8	180	1.0	180	1.8	110	1.0	110	500	4.4	2.2
HWG155	1.8	180	1.0	180	1.8	110	1.0	110	500	4.4	2.2
HWG180	2.7	270	1.5	270	2.7	165	1.5	165	500	4.4	2.2
HWG210	3.6	360	2.0	360	3.6	220	2.0	220	650	5.7	2.8
HWG270	3.6	360	2.0	360	3.6	220	2.0	220	650	5.7	2.8
HWG340	4.5	450	2.5	450	4.5	275	2.5	275	875	7.6	3.8

Model HWG Hot Gas Defrost | 50 Hz

Model	PSC Motor				EC Motor				Drain Pan Heaters		
	230/1/60		460/1/60		115/1/60		230/1/60		Watts	115/1/60	230/1/60
	Amps	Watts	Amps	Watts	Amps	Watts	Amps	Watts		Total Amps	
HWG100	1.7	160	0.8	160	1.8	110	1.0	110	320	2.9	1.5
HWG130	1.7	160	0.8	160	1.8	110	1.0	110	460	4.2	2.1
HWG155	1.7	160	0.8	160	1.8	110	1.0	110	460	4.2	2.1
HWG180	2.5	240	1.2	240	2.7	165	1.5	165	460	4.2	2.1
HWG210	3.3	320	1.6	320	3.6	220	2.0	220	595	5.4	2.7
HWG270	3.3	320	1.6	320	3.6	220	2.0	220	595	5.4	2.7
HWG340	4.2	400	2.0	400	4.5	275	2.5	275	800	7.3	3.6

DIMENSIONAL DATA

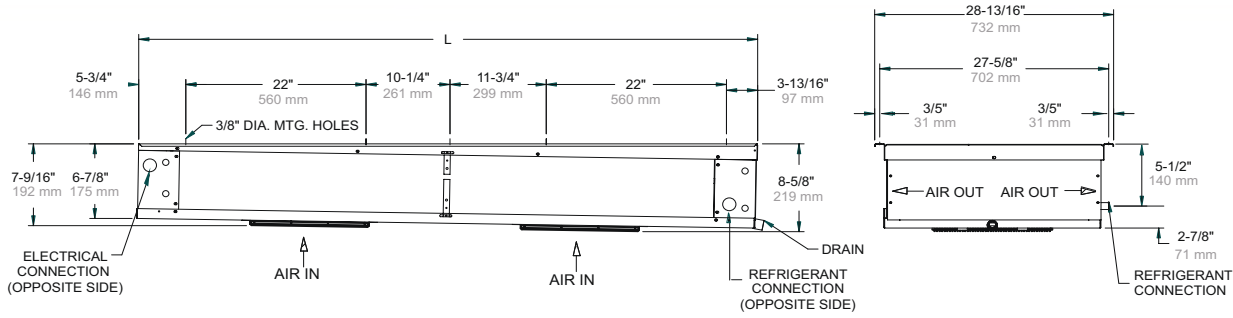

NOTE: All units have 1/4" OD external equalizer and 3/4" FPT drain connection

Model HWA Air Defrost

Model	No. of Fans	Dimensions	
		L In.	L mm
HWA050	1	31-1/2	800
HWA075	1	31-1/2	800
HWA100	2	53-1/2	1,359
HWA130	2	53-1/2	1,359
HWA155	2	53-1/2	1,359
HWA180	3	75-1/2	1,918
HWA210	4	97-1/2	2,477
HWA270	4	97-1/2	2,477
HWA340	5	119-1/2	3,035

Model HWE Electric Defrost

Model	No. of Fans	Dimensions	
		L In.	L mm
HWE050	1	31-1/2	800
HWE075	1	31-1/2	800
HWE100	2	53-1/2	1,359
HWE130	2	53-1/2	1,359
HWE155	2	53-1/2	1,359
HWE180	3	75-1/2	1,918
HWE210	4	97-1/2	2,477
HWE270	4	97-1/2	2,477
HWE340	5	119-1/2	3,035

Model HWG Hot Air Defrost

Model	No. of Fans	Dimensions	
		L In.	L mm
HWG100	2	53-1/2	1,359
HWG130	2	53-1/2	1,359
HWG155	2	53-1/2	1,359
HWG180	3	75-1/2	1,918
HWG210	4	97-1/2	2,477
HWG270	4	97-1/2	2,477
HWG340	5	119-1/2	3,035

Replacement Parts



Right source. Right parts. Right now.

InterLink™ is your link to a complete line of dependable and certified commercial refrigeration parts, accessories and innovative electronic controls for all Chandler equipment. At InterLink, we provide our wholesalers with a comprehensive selection of product solutions and innovative technologies for the installed customer base. And every product is built to ensure the same high performance standards with which all Heatcraft Refrigeration Products (HRP) brands are built — backed by a dedicated team to serve every customer need, delivering at the best lead times in the industry.

Dependable. Versatile. Courteous.

Finally, one simple source for all your replacement needs from a name you can trust.

For parts, please contact (800) 686-7278 or visit www.heatcraftprd.com.

No. of Fans	Air Defrost	Electric Defrost	Hot Gas Defrost
1	050-075	050-075	—
2	100-155	100-155	100-155
3	180	180	180
4	210-270	210-270	210-270
5	340	340	340

Electrical Components /Miscellaneous

Part #	Description	No. Fans
22512601	Terminal Strip	1 - 5
5521R	Defrost Termination	1 - 5
2891040	Room Thermostat	1 - 5
5708L*	Heater Safety	1 - 5
4550G	Filters	1 - 5

NOTE: * Not Required on WKE models

Motor/Fan Blade/Fan Guards

Part #	Description	No. Fans
5036NS	Motor 115/1/60/50 PSC	1 - 5
5036PS	Motor 208-230/1/60/50 PSC	1 - 5
25309701	Motor 460/1/60/50 PSC Totally Enclosed	1 - 5
25318001	Motor 115/1/60 EC Totally Enclosed	1 - 5
25317901	Motor 208-230/1/60/50 EC Totally Enclosed	1 - 5
5110E	Fan Blade	1 - 5
5055F	Fan Guard - Wire	1 - 5
41449101	Motor Mount - EC Motors	1 - 5
41417501	Motor Mount - 460v PSC	1 - 5

Cabinet Components

Part #	Description	No. Fans
C26769A2	Drain Pan-Stucco	1
C26771A2	Drain Pan-Stucco	2
C26361A2	Drain Pan-Stucco	3
C26362A2	Drain Pan-Stucco	4
D20817A2	Drain Pan-Stucco	5

Electric Defrost

Part #	Description	No. Fans
4401S	Coil Heater	1
4402S	Coil Heater	1
4544B	Coil Heater	2
4544B	Coil Heater	3
4545B	Coil Heater	4
4546B	Coil Heater	5

PHYSICAL DATA

HWA Air Defrost

Model	No. of Fans	Connections (in.)		Approx. Net Wt.	
		Liquid OD	Suction OD	lbs.	kg
HWA050	1	1/2	7/8	70	32
HWA075	1	1/2	7/8	103	47
HWA100	2	1/2	7/8	106	48
HWA130	2	1-1/8	1-1/8	145	66
HWA155	2	1-1/8	1-1/8	149	68
HWA180	3	1-1/8	1-1/8	160	73
HWA210	4	1-1/8	1-1/8	193	88
HWA270	4	1-3/8	1-3/8	200	91
HWA340	5	1-3/8	1-3/8	242	110

HWE Electric Defrost

Model	No. of Fans	Connections (in.)		Approx. Net Wt.	
		Liquid OD	Suction OD	lbs.	kg
HWE050	1	1/2	7/8	75	34
HWE075	1	1/2	7/8	108	49
HWE100	2	1/2	7/8	111	50
HWE130	2	1-1/8	1-1/8	150	68
HWE155	2	1-1/8	1-1/8	154	70
HWE180	3	1-1/8	1-1/8	157	71
HWE210	4	1-1/8	1-1/8	203	92
HWE270	4	1-3/8	1-3/8	208	94
HWE340	5	1-3/8	1-3/8	250	113

HWG Hot Gas Defrost

Model	No. of Fans	Connections (in.)		Approx. Net Wt.	
		Liquid OD	Suction OD	lbs.	kg
HWG100	2	1/2	7/8	131	59
HWG130	2	1-1/8	1-1/8	170	77
HWG155	2	1-1/8	1-1/8	174	79
HWG180	3	1-1/8	1-1/8	185	84
HWG210	4	1-1/8	1-1/8	223	101
HWG270	4	1-3/8	1-3/8	228	103
HWG340	5	1-3/8	1-3/8	270	122

Standard Nozzle Selection

Model HWA Air Defrost

Model	No. of Fans	Distributor Type		No. of Circuits	R404A, R507A Nozzle	R407A, R407F, R407C Nozzle	R448A R449A Nozzle	R22 Nozzle*
		OD	Length					
HWA050	1	3/16	18	3	L-1/3	L-1/3	L-1/2	L-1/4
HWA075	1	3/16	18	4	L-1/2	L-1/2	L-3/4	L-1/3
HWA100	2	3/16	18	6	L-3/4	L-3/4	L-1	L-1/2
HWA130	2	3/16	24	12	E-1	E-1	E-1-1/2	E-3/4
HWA155	2	3/16	24	10	E-1	E-1	E-1-1/2	E-3/4
HWA180	3	3/16	24	12	E-1-1/2	E-1-1/2	E-2	E-1
HWA210	4	3/16	24	12	E-1-1/2	E-1-1/2	E-2	E-1
HWA270	4	3/16	24	20	C-2	C-2	C-2-1/2	C-1-1/2
HWA340	5	3/16	24	20	C-2-1/2	C-2-1/2	C-4	C-2

Model HWE Electric Defrost

Model	No. of Fans	Distributor Type		No. of Circuits	R404A, R507A Nozzle	R407A, R407F, R407C Nozzle	R448A R449A Nozzle	R22 Nozzle*
		OD	Length					
HWE050	1	3/16	18	3	L-1/3	L-1/3	L-1/2	L-1/4
HWE075	1	3/16	18	4	L-1/2	L-1/2	L-3/4	L-1/3
HWE100	2	3/16	18	6	L-3/4	L-3/4	L-1	L-1/2
HWE130	2	3/16	24	12	E-1	E-1	E-1-1/2	E-3/4
HWE155	2	3/16	24	10	E-1	E-1	E-1-1/2	E-3/4
HWE180	3	3/16	24	12	E-1-1/2	E-1-1/2	E-2	E-1
HWE210	4	3/16	24	12	E-1-1/2	E-1-1/2	E-2	E-1
HWE270	4	3/16	24	20	C-2	C-2	C-2-1/2	C-1-1/2
HWE340	5	3/16	24	20	C-2-1/2	C-2-1/2	C-4	C-2

Model HWG Hot Gas Defrost

Model	No. of Fans	Distributor Type		No. of Circuits	R404A, R507A Nozzle	R407A, R407F, R407C Nozzle	R448A R449A Nozzle	R22 Nozzle*
		OD	Length					
HWG100	2	3/16	18	6	L-3/4	L-3/4	L-1	L-1/2
HWG130	2	3/16	24	12	E-1	E-1	E-1-1/2	E-3/4
HWG155	2	3/16	24	10	E-1	E-1	E-1-1/2	E-3/4
HWG180	3	3/16	24	12	E-1-1/2	E-1-1/2	E-2	E-1
HWG210	4	3/16	24	12	E-1-1/2	E-1-1/2	E-2	E-1
HWG270	4	3/16	24	20	C-2	C-2	C-2-1/2	C-1-1/2
HWG340	5	3/16	24	20	C-2-1/2	C-2-1/2	C-4	C-2

NOTE: Nozzles sized for 90-100°F liquid temperature at expansion valve. Contact Application Engineering for guidance if

- Liquid temperature is not 90-100°F
- Evaporator TD is not 10°-15°F (room temperature – saturated suction temperature)
- Electric defrost and hot gas models with a saturated suction temperature of 10°F or higher

Caution: Refrigeration system will not perform properly without correct nozzle!

*R-22 Nozzles for informational purposes only. Not included with stocking evaporators



2175 West Park Place Blvd. · Stone Mountain, GA 30087
Phone: 800.537.7775 · Fax: 770.465.5900
heatcrafterpd.com



Since product improvement is a continuing effort, we reserve the right to make changes in specifications without notice.

CH-LVTB-1118 | Version 001