

# ADIABATIC GAS COOLER

Technical Guide

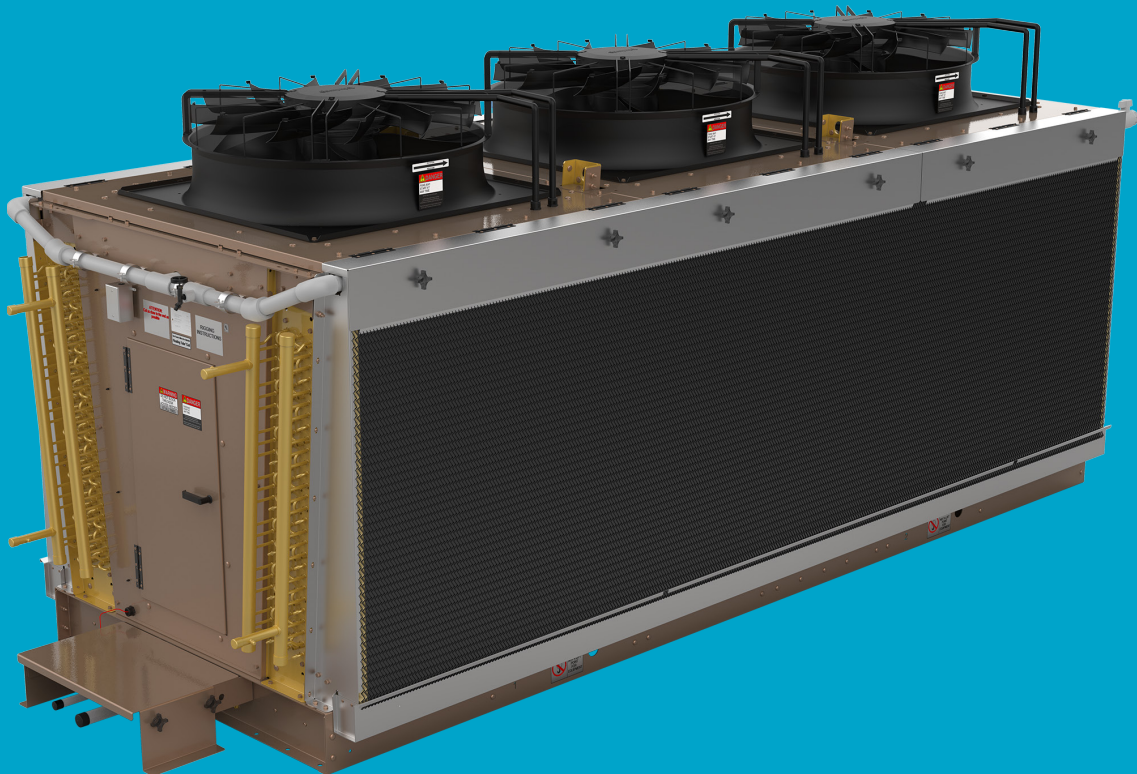

## ■ TABLE OF CONTENTS

<b>3</b>	<b>Nomenclature</b>
<b>3</b>	<b>Overview</b>
<b>4</b>	<b>Features</b>
<b>5</b>	<b>Performance Data</b>
<b>6</b>	<b>Specifications</b>
<b>8</b>	<b>Water Connections</b>
<b>9</b>	<b>Unit Weight</b>
<b>10</b>	<b>Adiabatic Gas Cooler Dimensions</b>



# NOMENCLATURE

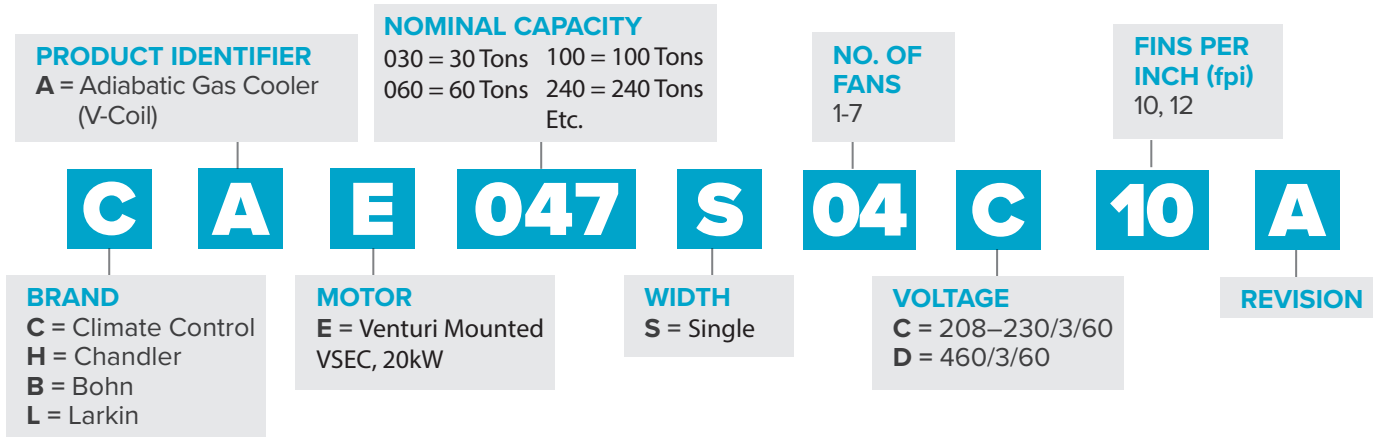

**Note:** Please consult your Sales Representative for 575/3/60 application requirements

# OVERVIEW

To meet the growing demand of CO<sub>2</sub> systems and to offer our customers a suite of product solutions to meet Low GWP regulations, Heatcraft Refrigeration is proud to offer the Adiabatic Gas Cooler product line specifically designed to be used in transcritical CO<sub>2</sub> applications. The Adiabatic Gas Cooler line offers our customers ample capacity range from 26 to 240 tons to satisfy an array of applications and uses the latest variable speed motor technology and water recirculation system to provide critical

sound and energy performance where significant energy savings are essential. The Adiabatic Gas Cooler product line is offered standard with a painted galvanized steel cabinet and stainless steel panels housing the water system.

The Adiabatic Gas Cooler is available with 1-7 fans in a single row configuration.



Venturi VSEC Mounted Motor Technology

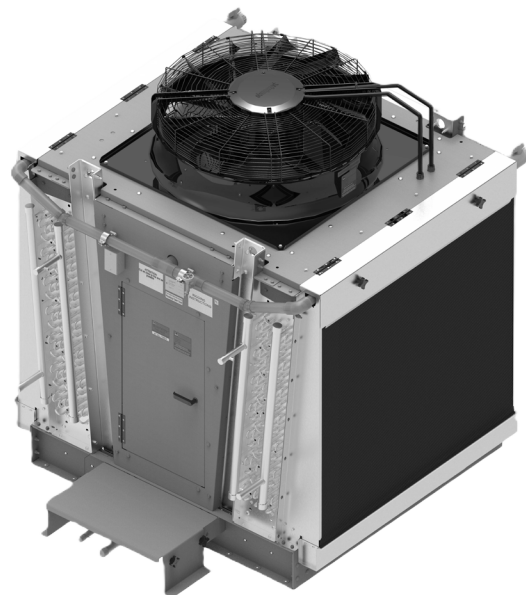

## FEATURES

The Adiabatic Gas Cooler is designed with features to meet specific customer requirements.

### STANDARD FEATURES INCLUDE:

- Variable speed EC motor with reversible flow for coil cleaning
- Broad capacity range from 26 to 240 tons
- 10 or 12 FPI coil
- Painted galvanized steel cabinet is standard with stainless steel used where there is contact with water.
- Hinged access panels for ease of maintenance
- Non-fused, through-the-door disconnect
- Coil design pressure is 1886psig and UL listed
- Coated coils standard for added corrosion resistance

### OUTSTANDING FEATURES

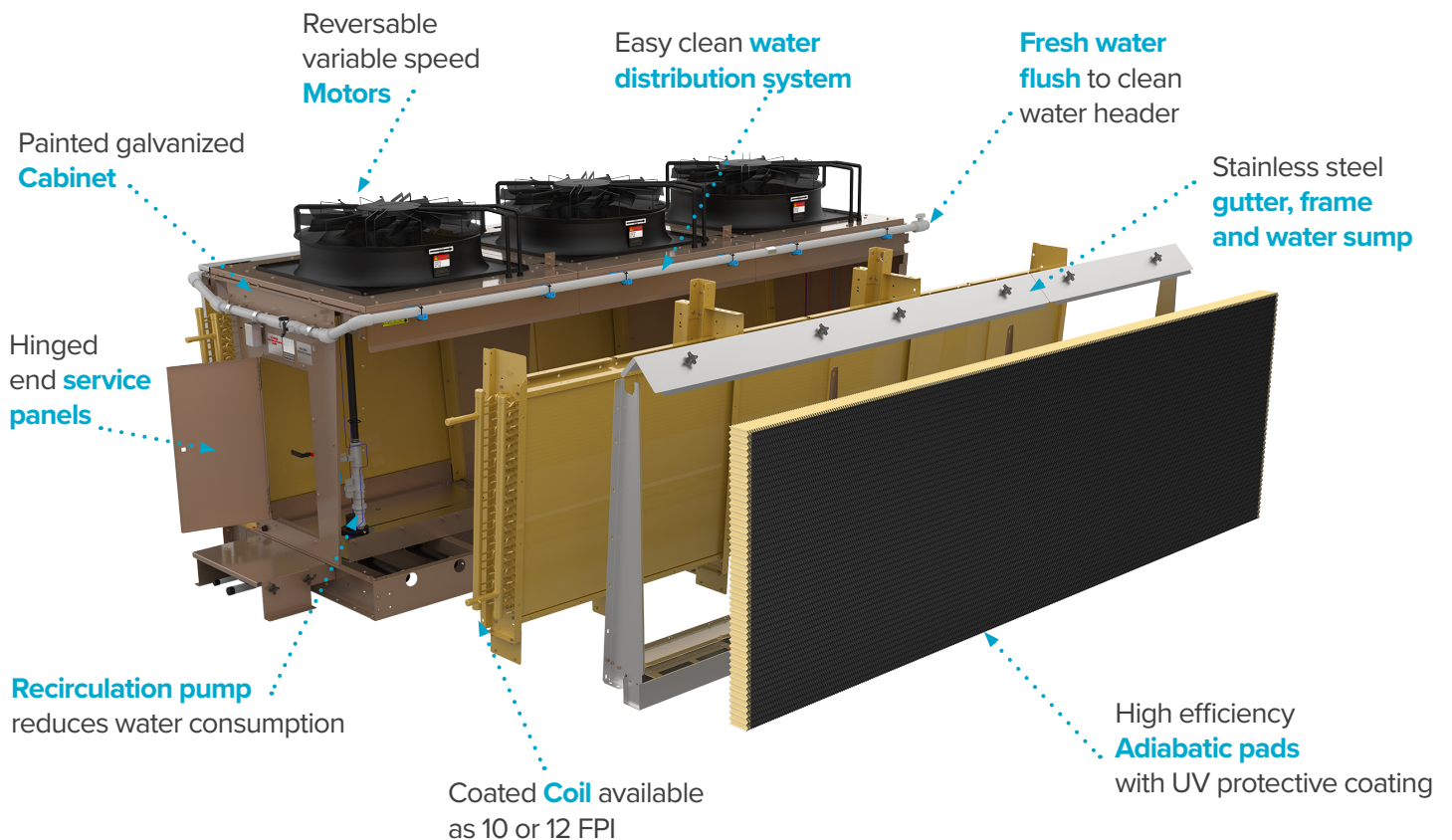

# PERFORMANCE DATA

Model	Fans	Capacity @ Dry bulb 100°F, Wet bulb 70°F, Gas cooler Inlet 195°F, Pressure Inlet 1110 Psia			
		10 FPI		12 FPI	
		Ton	MBH	Ton	MBH
CGE030S01^*A	1	26.8	322	28.9	347
CGE060S02^*A	2	53.7	644	57.9	695
CGE100S03^*A	3	89.16	1,070	97.9	1,175
CGE120S04^*A	4	107.5	1,290	115.8	1,390
CGE150S05^*A	5	136.5	1,638	147.4	1,769
CGE200S06^*A	6	184.6	2,215	203	2,436
CGE240S07^*A	7	217.6	2611	239.2	2,870

**Notes:**

^ = Electrical Code Designator (see Nomenclature details)

\* = Fins Per Inch (see Nomenclature details)

## SPECIFICATIONS

Model	Fans	Total CFM	208-230/3/60hz			Fan Power (KW)	Refrigerant Connections, Material	Circuits
			FLA	MCA	MOPD			
CGE030S01C*A	1	14,396	8.8	13.2	20	2.7	1-1/8", Copper	7
CGE060S02C*A	2	28,792	17.6	22	30	5.4	1-1/8", Copper	14
CGE100S03C*A	3	43,189	26.4	30.8	45	8.1	1-1/8", Copper	21
CGE120S04C*A	4	57,585	35.2	39.6	50	10.8	1-1/8", Copper	28
CGE150S05C*A	5	71,981	44	50.5	70	13.5	1-1/8", Copper	28
CGE200S06C*A	6	86,377	52.8	59.3	80	16.2	1-5/8", Copper	42
CGE240S07C*A	7	100,773	61.6	68.1	90	18.9	1-5/8", Copper	42

**Notes:**

\* = Fins Per Inch (see Nomenclature details)

# SPECIFICATIONS

Model	Fans	Total CFM	460/3/60hz			Fan Power (KW)	Refrigerant Connections, Material	Circuits
			FLA	MCA	MOPD			
CGE030S01D*A	1	14,396	5	7.35	15	2.7	1-1/8", Copper	7
CGE060S02D*A	2	28,792	10	12.35	15	5.4	1-1/8", Copper	14
CGE100S03D*A	3	43,189	15	17.35	25	8.1	1-1/8", Copper	21
CGE120S04D*A	4	57,585	20	22.35	30	10.8	1-1/8", Copper	28
CGE150S05D*A	5	71,981	25	28.45	40	13.5	1-1/8", Copper	28
CGE200S06D*A	6	86,377	30	33.45	45	16.2	1-5/8", Copper	42
CGE240S07D*A	7	100,773	35	38.45	50	18.9	1-5/8", Copper	42

**Notes:**

\* = Fins Per Inch (see Nomenclature details)

# WATER CONNECTIONS

Connections	Connection Size
Water In Line	Ø3/4" NPS, 316 SS
Water Drain Line	Ø1-1/4" NPS, 316 SS
Water Overflow Line	Ø2" OD, 316 SS
Emergency Water Inlet	Ø0.50" PVC BARBED HOSE CONNECTION
Water Header Drain	Ø1-1/2" WATER DRAIN (PVC)

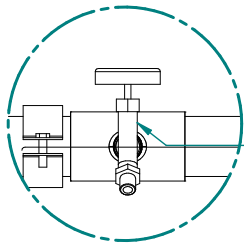

DETAIL A

EMERGENCY WATER INLET CONNECTION (Ø0.50" PVC BARBED HOSE CONNECTION)

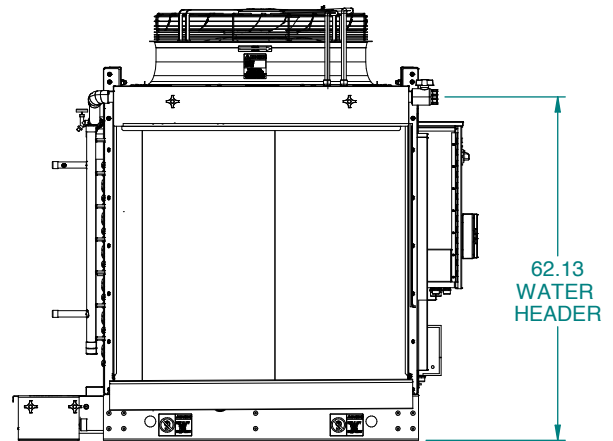
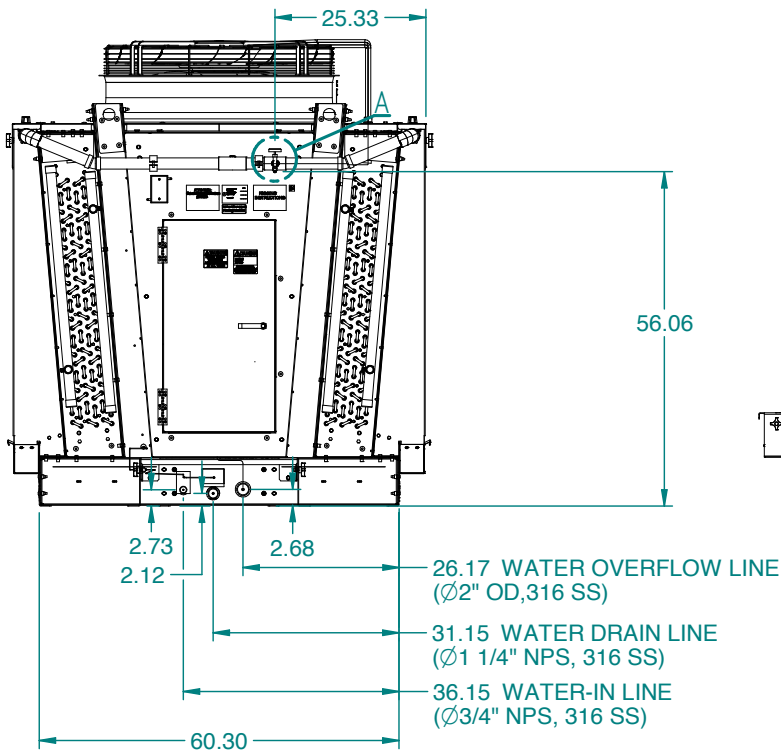
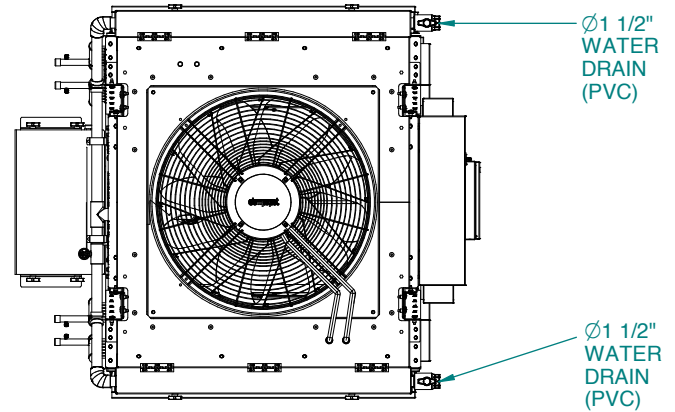

# UNIT WEIGHT

Model	Fans	Estimated Weight (lb)	
		10 FPI	12 FPI
CGE030S01^*A	1	2,064	2,084
CGE060S02^*A	2	3,551	3,581
CGE100S03^*A	3	4,642	4,682
CGE120S04^*A	4	5,940	6,000
CGE150S05^*A	5	7,465	7,535
CGE200S06^*A	6	8,722	8,802
CGE240S07^*A	7	9,793	9,893

**Notes:**  
 Estimated weight includes wooden Skid

# AGC GAS COOLER DIMENSIONS

END VIEW

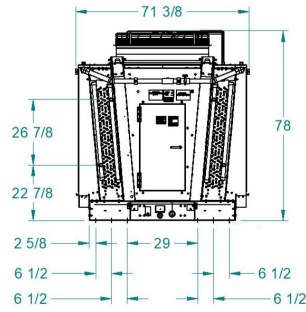

SIDE VIEWS

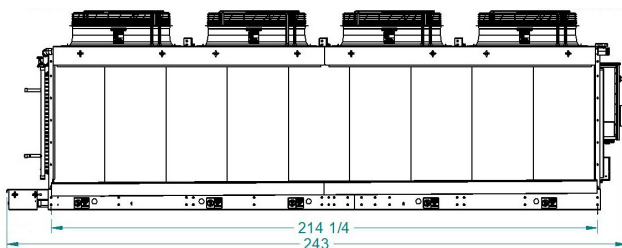
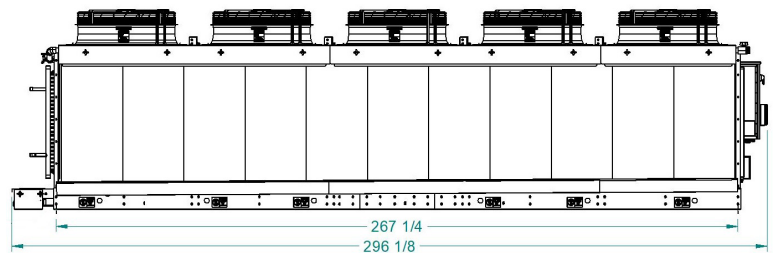
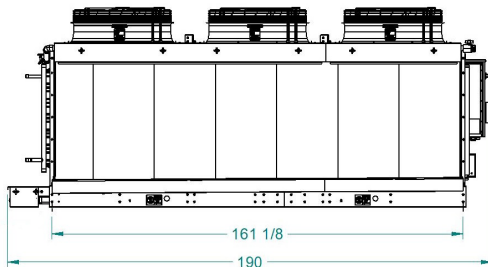
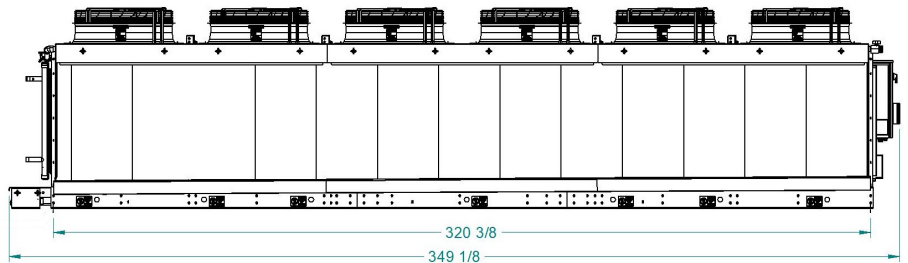
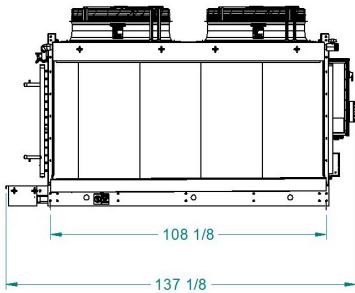
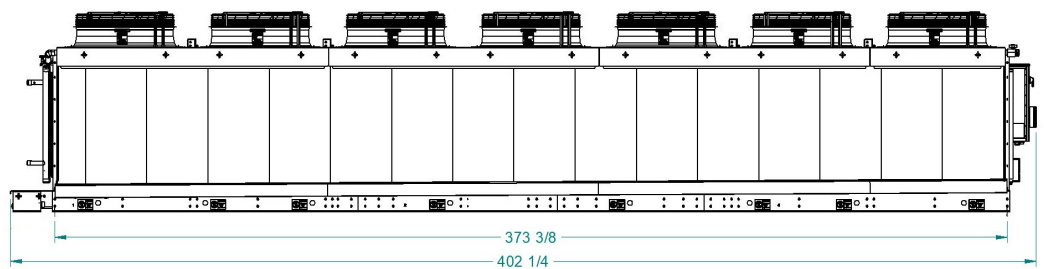
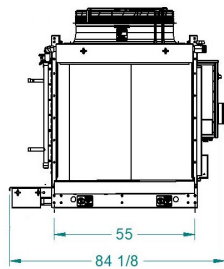

Model	Fans	Length	Width	Height
CGE030S01^*A	1	84 1/8"	71 3/8"	78"
CGE060S02^*A	2	137 1/8"	71 3/8"	78"
CGE100S03^*A	3	190"	71 3/8"	78"
CGE120S04^*A	4	243"	71 3/8"	78"
CGE150S05^*A	5	296 1/8"	71 3/8"	78"
CGE200S06^*A	6	349 1/8"	71 3/8"	78"
CGE240S07^*A	7	402 1/4"	71 3/8"	78"





2175 West Park Place Blvd.

Stone Mountain, GA 30087

Phone: 800.537.7775 · Fax: 770.465.5900

[heatcraftprd.com](http://heatcraftprd.com)

Since product improvement is a continuing effort, we reserve the right to make changes in specifications without notice.

**CC-AGC-1124 | Version 002**

©2024 Heatcraft Refrigeration Products LLC