

AIR COOLED CONDENSERS

Technical Guide

Models WSS



Table of Contents

Features & Options.....	2
Condenser Selection.....	3-4
Performance Data	5
Dimensional Diagrams	6
Dimensional Data	7
Specifications.....	7

WSS air-cooled condensers are available from 1 through 26 ton models. They are designed for efficient performance and low maintenance.



Design Features

- Horizontal or vertical air discharge
- Attractive aluminum housing
- Multi-circuiting at no additional charge
- Energy efficient fan motors with internal overload protection and permanently lubricated ball bearings
- Motors wired to a common junction box
- Coated steel fan guards
- Fully baffled fan sections to prevent windmilling

Available Options

- Factory mounted head pressure control valves (consult factory)
- Temperature or pressure activated fan cycling kits
- Control power transformer for fan cycling kits (230V standard)
- Alternate control voltages (115V or 24V) for fan cycling kits
- BohnGuard coated or copper fins on condenser coil
- Industrial coil coatings available (consult factory)
- Single phase fan motors available on all models
- Three phase motors available on models 005-026
- 575/3/60 motors available on models 005-026
- Sealtite wiring on models 005-026
- Variable speed fan motor options available on models 005-026 (consult factory)

CONDENSER SELECTION

Capacity for air-cooled condensers are based on total heat of rejection (THR) at the condenser. THR is equal to net refrigeration at the evaporator (compressor capacity) plus the energy input into the refrigerant by the compressor (heat of compression). The heat of compression will vary depending on the compressor manufacturer, type of compressor and the operating conditions of the compressor. Whenever possible, it is recommended that you obtain the heat of compression value from the compressor manufacturer.

If this is not available, the THR can be estimated using the following formula:

$$\text{THR} = (\text{Compressor Capacity}) * (\text{Heat of Compression Factor, Tables 1 \& 2})$$

Table 1 contains heat of compression factors for suction-cooled compressors and Table 2 contains factors for open drive compressors. For refrigeration systems beyond the range of Tables 1 and 2, use the following equations to estimate THR:

Open Compressors:

$$\text{THR} = \text{Compressor Capacity (BTUH)} + (2545) * (\text{Brake Horsepower, BHP})$$

Suction-Cooled Compressors:

$$\text{THR} = \text{Compressor Capacity (BTUH)} + (3413 * \text{KW})$$

The condenser capacity is affected by its altitude. If the condenser location is above sea level, an additional correction is required to the THR, as follows:

$$\text{THR (altitude)} = \text{THR} * \text{altitude Correction Factor, Table 3}$$

Table 1. Heat of Compression Factor for Suction-Cooled Compressors

Suction Temp. °F	Condensing Temperature °F				
	90°	100°	110°	120°	130°
-40°	1.56	1.63	1.72	1.81	1.94
-30°	1.49	1.55	1.62	1.70	1.80
-20°	1.43	1.49	1.55	1.62	1.70
-10°	1.38	1.43	1.49	1.55	1.63
0°	1.34	1.38	1.43	1.49	1.56
5°	1.31	1.36	1.41	1.48	1.55
10°	1.29	1.34	1.39	1.44	1.52
15°	1.26	1.31	1.36	1.41	1.48
20°	1.24	1.28	1.33	1.38	1.44
25°	1.22	1.26	1.31	1.36	1.42
30°	1.20	1.24	1.28	1.33	1.39
40°	1.17	1.20	1.24	1.28	1.33
50°	1.13	1.16	1.20	1.24	1.28

Table 2. Heat of Compression Factor for Open Drive Compressors

Evaporator Temp. °F	Condensing Temperature °F					
	90°	100°	110°	120°	130°	140°
-30°	1.37	1.42	1.47	—	—	—
-20°	1.33	1.37	1.42	1.47	—	—
-10°	1.28	1.32	1.37	1.42	1.47	—
0°	1.24	1.28	1.32	1.37	1.41	1.47
5°	1.23	1.26	1.3	1.35	1.39	1.45
10°	1.21	1.24	1.28	1.32	1.36	1.42
15°	1.19	1.22	1.26	1.30	1.34	1.40
20°	1.17	1.20	1.24	1.28	1.32	1.37
25°	1.16	1.19	1.22	1.26	1.30	1.35
30°	1.14	1.17	1.20	1.24	1.27	1.32
40°	1.12	1.15	1.17	1.20	1.23	1.28
50°	1.09	1.12	1.14	1.17	1.20	1.24

CONDENSER SELECTION

Step 1: Estimate Condenser THR

Obtain compressor heat of rejection from compressor manufacturer or calculate condenser THR estimate by multiplying compressor capacity by heat of compression factor from Tables 1 or 2 at given operating conditions.

$$\text{THR} = \text{Compressor Capacity} * \text{Heat of Compression Factor}$$

Step 2: Correct for Altitude

If condenser location is above sea level, correct for altitude by multiplying condenser THR by altitude correction factor from Table 3.

$$\text{THR} = \text{THR (from Step 1)} * \text{Altitude Correction Factor}$$

Step 3: Calculate Design Condenser T.D.

Design Condenser T.D.= Condensing Temp.– Ambient Temp.

Step 4: Condenser Selection

Condenser capacities for 60 Hz operation are located in Table 4. These capacities are given in MBH/°TD. Convert the THR calculated in step 2 to MBH/°TD by dividing by 1,000 to get THR in MBH. Then divide the THR by the design TD to get MBH/°TD.

Locate the capacity column and read down until you locate a value in the table equal to or just larger than the MBH/°TD calculated above. Read horizontally to the left and obtain the condenser model number.

$$\text{THR (MBH)} = \text{THR (from Step 2)} \div 1,000$$

$$\text{THR (MBH/°T.D.)} = \text{THR (MBH)} \div \text{Calculated Design Condenser T.D.}$$

Step 5: Calculate Actual Condenser T.D.and Condensing Temperature

Actual condenser T.D.can be calculated by dividing the design THR by the 1°F T.D.Condenser T.D.Rating.

$$\text{Actual T.D.} = \text{THR (MBH)} \div (\text{Rating at } 1^\circ\text{F})$$

Actual condensing temperature can be calculated by adding the actual condenser T.D.to the design ambient temperature.

$$\text{Actual Condensing Temp.} = \text{Ambient Temperature} + \text{Actual T.D.}$$

Table 3. Altitude Correction Factors

Altitude	Correction Factor
0	1.00
1,000	1.02
2,000	1.05
3,000	1.07
4,000	1.10
5,000	1.12
6,000	1.15
7,000	1.17

CONDENSER PERFORMANCE

Table 4. Performance Data for 60 Hz.

WSS Model	Capacity (MBH / 1°F)			
	R-404A / R-507	R-407C *	R-407A / R5407F	R-448A/R-449A *
008	0.74	0.94	0.73	0.73
010	1.00	1.88	0.98	0.99
016	1.54	2.82	1.51	1.52
024	2.38	4.70	2.33	2.36
040	3.92	7.52	3.84	3.88
049	4.77	9.40	4.67	4.72
061	5.96	11.28	5.84	5.90
070	6.85	13.16	6.71	6.78
080	7.83	15.04	7.67	7.75
105	10.29	19.74	10.08	10.19
113	11.07	21.62	10.85	10.96
133	13.03	24.44	12.77	12.90

* Based on midpoint condensing temperature

Table 5. Performance Data for 50 Hz.

WSS Model	Capacity (kcal / hr / 1°C)			
	R-404A / R-507	R-407C *	R-407A / R-407F	R-448A/R-449A *
008	310	291	304	307
010	420	395	412	416
016	640	602	627	634
024	990	931	970	980
040	1640	1542	1607	1624
049	1990	1871	1950	1970
061	2490	2341	2440	2465
070	2860	2688	2803	2831
080	3270	3074	3205	3237
105	4280	4023	4194	4237
113	4630	4352	4537	4584
133	5430	5104	5321	5376

* Based on midpoint condensing temperature

DIMENSIONAL DATA

Diagram 1. Dimensions for WSS Models 008 through 016

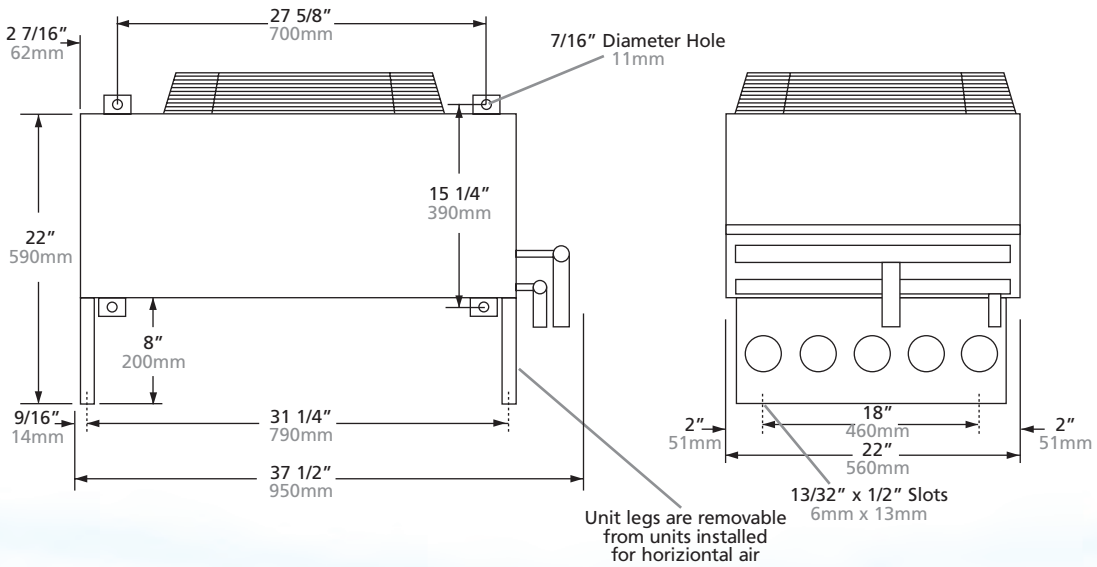

Diagram 2. Dimensions for WSS Models 024 through 133 with Vertical Air Flow

Note: These models could have 1, 2 or 3 fans - see table 6

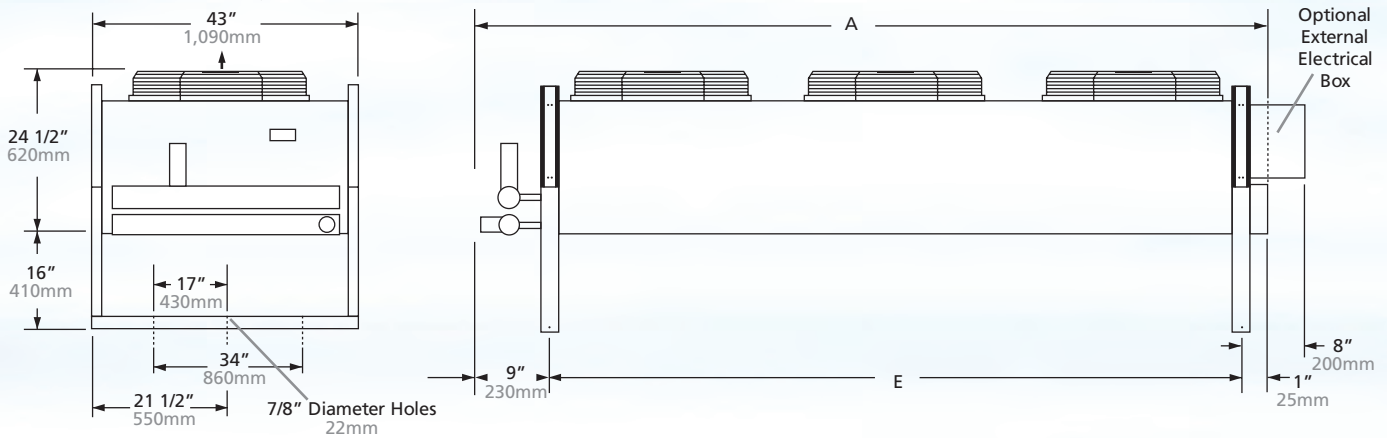
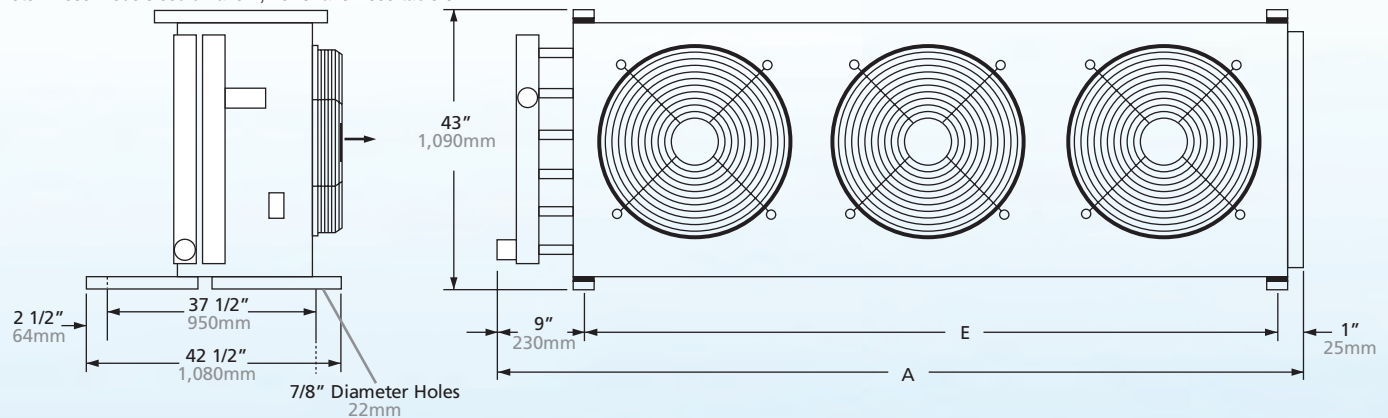

Diagram 3. Dimensions for WSS Models 024 through 133 with Horizontal Flow

Note: These models could have 1, 2 or 3 fans - see table 6



CONDENSER SPECIFICATION / CONDENSER FAN CYCLING

Table 6. Physical Specifications

WSS Models	CFM/m³h		Fan			Motor Data					
			No.	Dia. In./mm		HP¹	FLA¹	HP²	FLA²	HP³	FLA³
008	2400	4100	1	18	460	1/4	2.0	---	---	---	---
010	2400	4100	1	18	460	1/4	2.0	---	---	---	---
016	2100	3600	1	18	460	1/4	2.0	---	---	---	---
024	5050	8600	1	24	610	1/3	3.4	1/3	2.6/1.3	1/3	1.0
040	6450	11000	1	26	660	1/2	3.9	1/3	2.6/1.3	1/3	1.0
049	10100	17200	2	24	610	1/3	6.8	1/3	5.2/2.6	1/3	1.9
061	12400	21100	2	26	660	1/2	7.8	1/3	5.2/2.6	1/3	1.9
070	13700	23300	2	26	660	1/2	7.8	1/3	5.2/2.6	1/3	1.9
080	12900	21900	2	26	660	1/2	7.8	1/3	5.2/2.6	1/3	1.9
105	20500	34800	3	26	660	1/2	11.7	1/3	7.8/3.9	1/3	2.9
113	19900	33800	3	26	660	1/2	11.7	1/3	7.8/3.9	1/3	2.9
133	19400	33000	3	26	660	1/2	11.7	1/3	7.8/3.9	1/3	2.9

¹ Motor voltage 208-230/1/60; 1100 RPM nominal
 ² Motor voltage 208-230-460/3/60; 1100 RPM nominal
 ³ Motor Voltage 575/3/60; 1100 RPM nominal

Note: WSS 008-010 available in 115/1/60 voltage

WSS Models	Dimensions Inches/mm				Connections ODS (In.)		Max. Feeds Avail.	Approx. Net Wt. Lbs./kg	
	A		E		Inlet	Outlet			
008	---		---		3/8	3/8	1	96	44
010	---		---		7/8	5/8	2	96	44
016	---		---		7/8	5/8	4	114	52
024	40	1010	30	760	1-1/8	7/8	8	180	82
040	50	1260	40	1020	1-1/8	7/8	16	260	118
049	70	1770	60	1520	(2) 1-1/8	(2) 7/8	16	450	204
061	70	1770	60	1520	(2) 1-1/8	(2) 7/8	16	470	213
070	90	2280	80	2030	(2) 1-1/8	(2) 7/8	16	510	231
080	90	2280	80	2030	(2) 1-3/8	(2) 1-1/8	32	530	240
105	130	3300	120	3050	(2) 1-5/8	(2) 1-1/8	24	550	249
113	130	3300	120	3050	(2) 1-5/8	(2) 1-1/8	24	580	263
133	130	3300	120	3050	(2) 1-5/8	(2) 1-1/8	32	625	284

Condenser Fan Cycling

WSS models 049 to 133 condensers are available with either ambient or pressure activated fan cycling packages. Head pressure can be controlled by varying the air flow across the coil in response to changes in ambient temperatures or refrigerant pressures. See Table 7 below for minimum ambients for fan cycling.

Table 7. Minimum Ambient for Fan Cycling (90°F/32°C Condensing Temperature)

WSS Models	Fans	Design T.D.									
		30°F/ 17°C.		25°F/ 15°C.		20°F/ 12°C.		15°F/ 8°C.		10°F/ 6°C.	
049, 061, 070, 080	2	35	2	45	7	55	13	60	16	70	21
105, 113, 133	3	15	-9	30	-1	40	4	55	13	65	18



2175 West Park Place Blvd.

Stone Mountain, GA 30087

Phone: 800.537.7775 · Fax: 770.465.5900

heatcraftprd.com

Since product improvement is a continuing effort, we reserve the right to make changes in specifications without notice.

CH-RACCTG-0922 | Version 005

©2022 Heatcraft Refrigeration Products LLC